

# Maintenance Instructions

**MS52-6.3**

## Disclaimer

The illustrations in this documents may deviate from the delivered product. We reserve the right to make changes due to errors or based on technical advances.

## A Word on Copyright

This document is proprietary and was originally written in German. Its reproduction and distribution in whole or in individual parts without permission of the copyright owner is prohibited and will be prosecuted under criminal or civil law. All rights reserved, including for translation.

© Copyright by INDEX-Werke GmbH & Co. KG Hahn & Tessky

## Table of contents

<b>Preface</b> .....	<b>1</b>
General notes.....	1
Safety Instructions.....	1
<b>Service Interval - Care activities</b> .....	<b>7</b>
Maintenance Summary - Care activities.....	8
AM012 - Check the work area door and window pane.....	9
AM016 - Check the pressures on the machine.....	11
AM028 - Check hydraulic and lubrication systems.....	12
AM030 - Visual inspection of all fluid lines and electrical cables.....	15
AM032 - Check pre-pressure of pressure accumulators.....	17
AM035 - Replace the breathing filter at the filler neck of the hydraulic fluid tank.....	19
AM040 - Check pneumatic system (visual inspection).....	21
AM053 - Checking foldable steps (visual inspection).....	23
AM055 - Cleaning of the machine.....	26
AM060 - Swiveling synchronous: Check swivel axes.....	28
AM065 - Check Stäubli robot.....	29
AM080 - Clean and lubricate chucks.....	30
AM095 - Check work area light (visual inspection).....	31
AM100 - Clean cooling lubricant outlet on spindle carrier.....	33
AM110 - Check the window pane at the level sensor of the vacuum rotation filter.....	35
AM123 - Checking the coolant - option 1.....	37
AM125 - Checking the coolant - option 2.....	39
AM138 - Removing clamping element holder.....	41
AM240 - Locking the spindle.....	44
AM320 - Clean collets and base body.....	46
AM337 - Remove, inspect, lean and reinstall the spindle liner tubes.....	51
AM340 - Visual inspection of the fire extinguishing system.....	53
AM370 - Check gas springs on the control cabinet door, replace if necessary.....	54
<b>Service Interval - 1.000 Operating hours</b> .....	<b>57</b>
Maintenance Summary - 1.000 Operating hours.....	58
BM010 - Customer area.....	59

<b>Service Interval - 2.000 Operating hours.....</b>	<b>61</b>
Maintenance Summary - 2.000 Operating hours.....	62
CM010 - Checking the inspection and maintenance schedules/logs.....	63
CM030 - Check hydraulic system.....	64
CM046 - Replace hydraulic fluid filters.....	67
CM048 - Replacing the hydrostatic filter.....	69
CM052 - Fluid cooling - oil filters for heat exchangers, spindle carriers and synchronizers.....	73
CM060 - Check pre-pressure of pressure accumulators.....	76
CM080 - Inspection of water cooling equipment (option).....	78
CM140 - Inspection of the pneumatic system.....	79
CM180 - Checking the window pane.....	82
CM270 - Check MS guard switch/interlock.....	83
CM290 - Check IEMCA loading and unloading system.....	84
CM330 - Check gas springs on the control cabinet door, replace if necessary.....	85
CM480 - Check operating panel for general condition.....	88
<b>Service Interval - 5 Years.....</b>	<b>89</b>
Maintenance Summary - 5 Years.....	90
IM020 - Replace the pressure accumulator.....	91
<b>Service Interval - 8 Years.....</b>	<b>95</b>
Maintenance Summary - 8 Years.....	96
JM030 - Replace the window pane.....	97

## Preface

## General notes

The maintenance activities described in this document essentially pertain only to the machine. Maintenance activities of auxiliary units (e.g., bar loading magazines, extraction systems) are described in the documentation of the specific manufacturer.

The maintenance and servicing activities must absolutely be observed. Failure to conduct maintenance and servicing in accordance with these instructions (especially not at the respective intervals) rules out any claims for damages. This does not apply if it is proved that the non-compliance with the maintenance and servicing activities is unrelated to the defect. Normal wear and tear, especially of components such as bearings and seals, is not a defect. These components are therefore excluded from the warranty. It is recommended to keep a written log of all maintenance activities carried out.



**INDEX multi-spindle lathes** generally require cutting oil (based on mineral oil) as a cooling lubricant. The use of unsuitable water-based cooling lubricants (so-called emulsions) or of cutting oils that are not based on mineral oil can cause considerable damage to the machine. Therefore, such cooling lubricants may be used only with prior written approval by **INDEX**. The resulting requirements for increased maintenance must be followed carefully. Considering the interactions between cooling lubricant, the material used in each case, any additives, etc., **INDEX**'s approval is limited to the basic safety of using the cooling lubricant on the machine. The testing and avoidance of interactions are the responsibility of the operator, **INDEX** rejects any liability. Be sure to conduct adequate tests prior to production use.

**Maintenance intervals**

The maintenance intervals are given based on the operating hours counter / "Hydraulic system On" operating condition.

**Maintenance intervals displayed on the controller (iXpanel)**

Depending on the respective machine type and the different controller types, a corresponding message is issued on the controller when a maintenance interval is reached. The maintenance instructions stored on the respective controller provide information (maintenance log) explaining the service and maintenance activities to be performed.



### Cleaning of the machine

#### Do not clean the machine with compressed air

- Raised dirt particles may cause breathing difficulty or injury (especially of the sensory organs). Furthermore, raised dirt particles or chips may reach spots where they cause technical problems.

#### Do not use cotton waste for cleaning

- When cleaning with cotton waste, fibers or thread can get loose causing safety problems.

#### Solvents

- Do not use highly volatile solvents such as petroleum spirit, trichloroethylene or similar cleaning agents. These cleaners may damage the seals, which can lead to safety problems.

#### Pressure washers

- Do not clean the machine with a pressure washer. Cleaning with a pressure washer results in strong corrosion. Furthermore, bearings may be degreased, and seals may become leaking, which can lead to safety problems.



### Cleaning of tool mountings

A suitable cleaning tool must be used to clean the hole in the tool mounting.



### Ordering spare parts

Always specify the machine type and machine number when ordering spare parts. This and other information about the machine are located on the nameplate under the main switch of the control cabinet.



### Operating material

For all work in connection with operating materials, the information in the data sheets of the respective manufacturers and the information in the document **Notes on Operating Materials**.



### Pressure accumulators $\leq 1$ L

Pressure accumulators with a volume of  $\leq 1$  L are **not** subject to testing and labeling according to the current issue of the pressure equipment directive. The guidelines and regulations applicable in the country of use must be followed.

## Safety Instructions

**Safety Instructions and Technical Details**

The user documentation and, in particular, the document “**Safety Instructions and Technical Details**” must be observed.

**Carrying out maintenance work****Authorized and trained personnel**

- Maintenance is to be performed only by authorized and trained personnel. This applies particularly to work on motors (spindle motors) or other electrical assemblies. The instructions in the respective manufacturer documentation must be followed for such work.

**Allow the machine to cool down**

- Prior to working on the machine, it must be allowed to cool down, as hot parts may be located under the covers.

**Maintenance work on machine being switched off**

- In general, maintenance is to be carried out with the machine switched off. The main switch must be locked out. Even when the main switch is switched off, parts of the machine (e.g., the control cabinet light) may still carry electricity. These parts are labeled. In a few cases, maintenance work needs to be performed with the machine turned on (e.g., replacement of backup batteries). These maintenance activities must be carried out with special care.

**Required tools**

- For removing machine parts, suitable lifting gears and a variety of tools must be used. Removed machine parts must be placed in a safe position and secured against falling over.
- All maintenance work on the machine must be carried out with utmost care. Fasteners must be loosened carefully and parts must be secured against falling down. When elastic items (springs) are removed/replaced, appropriate devices must be used. Any (non-horizontal) axes that pose a risk of falling down must be moved to their end positions or secured against falling down. Pedal switches must be put aside to avoid inadvertent actuation.

**Performing maintenance, repair or service work**

- The currently valid safety regulations, as well as the specific manufacturer's information for the intended use must be observed for these activities.

**Use of climbing aids (ladders or steps)**

- In addition, appropriate climbing aids may be required to carry out these activities. When working on climbing aids at great heights, e.g., on the control cabinet, these must always be secured or fastened (depending on the machine, eyelets are also provided for this purpose).

**Procurement/use of spare parts**

We recommend the use of original spare parts and accessories. For damages caused by the use of parts from third-party providers, liability and warranty are excluded. The use of such products may change the structural characteristics of the machine and negatively affect active or passive safety.

**Cellular and cordless phones**

When the control cabinet is open or the machine covers are open or removed, no cellular or cordless phones may be used within a <2 m radius.

**Coolant**

The following must be observed when handling coolants:

When refilling, only the specified coolant ( label on the coolant tank/ cooling unit) may be filled in. If there is no label on the container/ cooling unit, the coolant already used must be refilled.

The entire cooling system must be carefully cleaned and rinsed several times with clean water before refilling with new coolant.

Mixing different coolants may trigger biological/chemical reactions and cause consequential damage to components.





### Handling hydraulic and hose lines

Damaged hydraulic hose lines must be replaced immediately. Typical types of damage include chafing, kinks, cracks, deformations, or visible leaks.

Flexible, pressurized hydraulic hose lines of **INDEX** equipment are generally designed as thermoplastics or metallic hydraulic hose lines.

The machine operator/owner is responsible for compliance with the laws and regulations of the country of use with regard to the use of hydraulic hoses.

We recommend inspection and documentation of the hydraulic hose lines installed inside the machine and not directly visible every 12 months. For hydraulic hose lines visible in the work area or mounted outside the machine and connecting components to the machine, we recommend inspection and documentation every 6 months.

For the flexible, pressurized hydraulic hose lines used by **INDEX**, empirical values are available for very different periods of use, some of which exceed 10 years.



### Maintenance work on fluid systems (hydraulic, lubrication, and pneumatic systems)

When carrying out maintenance work on fluid systems (hydraulic, lubrication, and pneumatic systems), make sure **before** starting the work that the respective system **has been depressurized** (accumulator drain valve / manual slide valve).



### Dry run or functional test

After all maintenance work and work on electrical assemblies, a dry run or functional test must be performed.



**Service Interval - Care activities**

## Maintenance Summary - Care activities



It is recommended to document the maintenance activities carried out by using the appropriate maintenance log. The maintenance log has the document number DIM028EN - 25.03.2024.



The maintenance interval is highly dependent on the production and environmental conditions of the machine. The determination of the appropriate interval must be made by the operator.

**The maintenance interval should be between once per shift and once a week!**

- AM012** - Check the work area door and window pane
- AM016** - Check the pressures on the machine
- AM028** - Check hydraulic and lubrication systems
- AM030** - Visual inspection of all fluid lines and electrical cables
- AM032** - Check pre-pressure of pressure accumulators
- AM035** - Replace the breathing filter at the filler neck of the hydraulic fluid tank.
- AM040** - Check pneumatic system (visual inspection)
- AM053** - Checking foldable steps (visual inspection)
- AM055** - Cleaning of the machine
- AM060** - Swiveling synchronous: Check swivel axes
- AM065** - Check Stäubli robot
- AM080** - Clean and lubricate chucks
- AM095** - Check work area light (visual inspection)
- AM100** - Clean cooling lubricant outlet on spindle carrier
- AM110** - Check the window pane at the level sensor of the vacuum rotation filter
- AM123** - Checking the coolant - option 1
- AM125** - Checking the coolant - option 2
- AM138** - Removing clamping element holder
- AM240** - Locking the spindle
- AM320** - Clean collets and base body
- AM337** - Remove, inspect, lean and reinstall the spindle liner tubes
- AM340** - Visual inspection of the fire extinguishing system
- AM370** - Check gas springs on the control cabinet door, replace if necessary

## AM012 - Check the work area door and window pane



Carrying out the maintenance activities described below requires special knowledge. For this reason, these maintenance activities must only be carried out by staff that has received adequate training by the machine manufacturer!

### Orientation

Inspection and maintenance of the work area door includes several steps:

- Inspection of the window pane for damage,
- Checking the safety label on the window pane,
- Checking the work area door for smooth opening/closing,
- Functional testing of the safety interlock.

The window pane consists of four panes, the inner pane made of tempered glass, two center panes made of polycarbonate, and an outer pane also made of polycarbonate. The inner pane is relatively resistant to chemical substances. It can be cleaned with any commercially available cleaning agents. Only the center pane is essential for the impact resistance of the window pane.

The polycarbonate panes are subject to **natural** aging and therefore must be subjected to regular visual inspection. Through contact with cooling lubricant, the aging process is accelerated even further.



Damage to the window pane by improper cleaning.

- Do not use sharp objects such as razors or screwdrivers.
- Do not use abrasive or alkaline cleaning agents such as petroleum spirit, benzene, acetone, or carbon tetrachloride (tetrachloromethane).



**If a workpiece has hit an inspection window, the viewing and laminated panes must be replaced immediately by the INDEX service. This is necessary regardless of the extent of damage. Even with minimal damage, the impact resistance of the pane can no longer be guaranteed.**

Check the guide rails of the work area door. The guide bars must be checked and cleaned regularly so that the work area door can be moved without much effort.

### Requirement

For cleaning, only:

- a soft cloth or sponge
- cleaning solution of water and soap
- isopropyl alcohol (45%)
- isobutyl alcohol
- ethyl alcohol
- methyl alcohol
- white spirit

must be used.

## Procedure

1. Check window pane for damage.

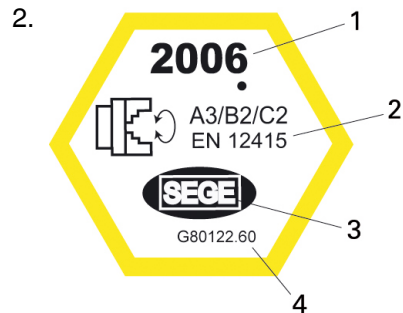

**Example: Safety label – window pane 2006**

- 1 Year of manufacture
- 2 Protection class and EN standard
- 3 Manufacturer
- 4 INDEX part number

Check safety label of the window pane.

3. Clean outer pane (window pane).

4. Clean inner pane (single-pane compound glass).

5. Check the work area door for ease of movement. To do so, open and close the work area door. If the work area door can be moved only with effort, determine the cause. Possible causes are chips on the guide bar or in the guide rollers of the work area door.

6. Check the locked/unlocked function of the safety interlock.

**AM016** - Check the pressures on the machine

## Orientation

The different pressures of the central lubrication system, hydrostatic system and the system pressure must be checked regularly.



If there are ambiguities regarding the pressure values, be sure to consult the fluid diagrams included in the machine documentation/ documentation CD.

## Requirement



Pressures on the machines: MS16-6, MS16-6 Plus, MS22-6, MS22-8, MS32-6.2, MS40-6, MS40-8, MS52-6.3

- Central lubrication system **30 bar**
- Hydrostatic pressure **50 bar**
- System pressure (hydraulics) accumulator loading operation **92-102 bar**

## Procedure

1.



The pressure values specified here must absolutely be observed. If the values specified here differ from the values on the machine, be sure to contact the **INDEX** hotline, **INDEX** service or an **INDEX** representative.

Check pressure values

## AM028 - Check hydraulic and lubrication systems



Carrying out the maintenance activities described below requires special knowledge. For this reason, these maintenance activities must only be carried out by staff that has received adequate training by the machine manufacturer!

## Orientation

Operating fluids such as hydraulic fluids, cooling lubricants, lubricating greases/oils are also subject to degradation or aging as the components involved in this process, and must therefore be serviced, refilled or replaced at regular intervals. Do not use cotton waste and highly volatile solvents such as petroleum spirit, trichloroethylene or similar cleaning agents. The machine must not be cleaned with compressed air. To ensure trouble-free operation, periodic checks of the oil level are necessary. The fill level must be between the upper and lower marks on the oil sight glass.

During maintenance of the lubrication system, first perform a visual inspection of all components involved in lubrication for leaks and their visual condition. The following components must be examined during maintenance of the lubricating oil system:

- Pressure gauges
- Metering valves
- Pressure sensors
- Fluid lines belonging to the lubricating oil supply



For all work in connection with operating fluids, the information in the data sheets of the respective manufacturers and the information in the document **Information on operating fluids** must be followed.



Screws on the hydraulic system, the connected components, and the supply lines must be tightened to the manufacturer's specified torques.



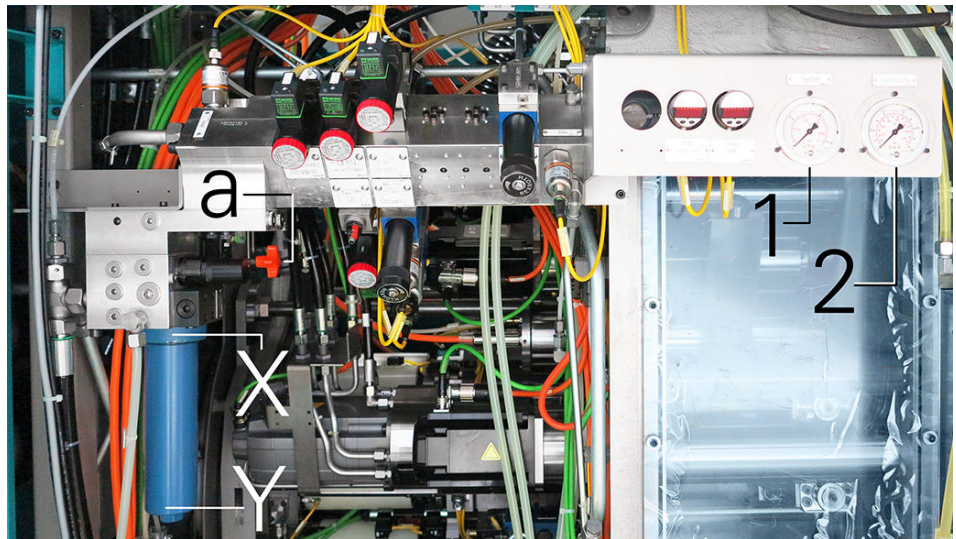

Example: Hydraulic unit MS52-6.3

- a Accumulator drain valve
- 1 Pressure gauge for system pressure
- 2 Hydrostatic pressure gauge
- X Hydraulic fluid filter
- Y Filter bowl

## Requirement



Depressurize the hydraulic and lubrication systems by opening the accumulator drain valve.

Power off the machine and secure it against accidental power on.

The maintenance of the lubricating oil supply requires the following auxiliary or working equipment:

- servicing, testing and maintenance schedules/logs of the customer.
- Use an ample supply of cleaning rags - **no cotton waste**.
- A sufficient amount of hydraulic fluid or lubricating oil. - **Oil type, specification and quantity as specified in the technical data.**
- To avoid impurities in the hydraulic system, **pre-filter the oil to be refilled with 3μ.**
- Replacement filters. – **Use only original filters.**
- Various sizes of jaw and box wrenches, and Allen keys.

## Procedure

1.



The hydraulic fluid and lubricating oil levels should always be near the top mark when the machine is switched off. During production, the oil level may drop after several consumers have been connected.

Check oil level at the oil sight glass.

2. Visual inspection of the hydraulic fluid or lubricating oil. The fluid or oil may not exhibit any foaming or cloudiness at the oil sight glass. In case of problems of

this kind, immediately determine the cause and correct the error. If in doubt, take a sample for analysis and contact the manufacturer of the fluid or oil.

3.  If more than 49 L of hydraulic fluid have to be refilled within 21 working shifts or one week, the hydraulic system must be checked for leaks.

Check for leakage. Also check all screw connections and fluid lines, as well as all hydraulic devices such as valves, sensors and filters of the system

4.  **Pressurized fluids exiting from damaged or incorrectly installed fluid lines.**  
**General cuts or eye injuries.**  
Power off the machine and depressurize the hydraulic system before any maintenance activities. Secure the machine against being switched on. Wear personal protective equipment.

Check fluid lines for damage such as buckling and abrasions, and for liquid leaks. If necessary, replace fluid lines. Record the age or date of replacement of the fluid lines. Enter in the service, testing and maintenance schedules or logs.

**Alternatively, the following procedure can be used!**

If immediate replacement of the fluid line(s) is not possible, determine the part data and order the fluid line(s). If necessary, consult the machine manufacturer or its representative as when schedule the replacement.

5. Conduct a finger test of screw connections, fittings, etc. to see whether they are wet, and check for tightness.

**Alternatively, the following procedure can be used!**

Tighten loose and/or wet screw connections.

6. Check components for damage.

**Alternatively, the following procedure can be used!**

Log damage to components and initiate follow-up measures such as ordering, and schedule the replacement with the machine manufacturer or its country representative.

## AM030 - Visual inspection of all fluid lines and electrical cables

### Orientation

Depending on the duration of use, usage profile of the machine and different ambient conditions, it is absolutely necessary to subject all fluid lines and electrical cables to regular visual inspections. This allows that any faults or problems can be detected and eliminated early on.



Leave the immediate area around the machine and the additional units free; do not use it as storage or warehouse space. This significantly reduces the risk of damage to electrical lines.

Electrical lines routed outside the machine (e.g., lines for cooling lubricant systems, chip conveyor, and pedal switch) must be regularly checked for damage (e.g., pinching or cuts).



Damaged fluid lines may cause leakage of fluids under high pressure. Be sure to use personal protective equipment during visual inspection.

### Requirement

Should defective points be found on fluid lines or electrical cables during the visual inspection, the machine must be switched off and the damaged lines or cables must be promptly replaced.



Replaced fluid lines must be tightened to the torque specified by the manufacturer.

### Procedure

1. Visual inspection of all fluid lines.

2.



Caution

**Electrical equipment or parts thereof are under dangerous voltage.**

**Electric shock.**

Switch off the machine and lock it out.



Checking the supply lines of add-on equipment:

1. Chip conveyor
2. Cooling oil/lubricant supply
3. Workpiece feeders (robots, bar loaders or bar loading magazines)
4. Workpiece removal units (robots)
5. Additional or handheld control unit
6. Other optional accessories

Have damaged cables replaced immediately by a qualified electrician.

Visual inspection of all electrical cables.

## AM032 - Check pre-pressure of pressure accumulators



Carrying out the maintenance activities described below requires special knowledge. For this reason, these maintenance activities must be carried out only by authorized personnel of the manufacturer!

### Orientation



The activities described here are only permitted to be carried out after training or instruction by the manufacturer of the pressure accumulator.

A pressure accumulator consists of two chambers, a liquid and a gas section with a membrane as a separator. The liquid section is connected to the hydraulic circuit, so that the bubble reservoir is filled when the pressure rises, thereby compressing the gas. When the pressure drops, the compressed gas expands and displaces the stored pressurized liquid into the circulation. This ensures that the pressure level is maintained during load changes or temporary higher loads.



Screws on the hydraulic system, the connected components, and the supply lines must be tightened to the manufacturer's specified torques.

### Requirement



If there are ambiguities regarding the pressure values, be sure to consult the fluid diagrams included in the machine documentation/ documentation CD.



The values for pressure accumulator pre-tension of each machine type<sup>1</sup> are:

- MS16-6, MS22-6, MS22-8, MS24-6 **68 bar**
- MS32-6.2, MS32-6.3, MS40-6, MS40-8, MS52-6.3 **68 bar**

<sup>1)</sup> The pressures of the accumulator pre-tension is indicated on a label on the pressure accumulators.

### Procedure

1. Check the pressure accumulator. While the machine is switched on (not during a program or continuous run), press the emergency stop switch, while watching the system pressure gauge. The indication on the pressure gauge should drop noticeably within a few seconds. From a certain value (see info – Pretension pressures), the pressure drops rapidly to 0 bar. It is assumed that the accumulator pre-tension, the accumulator membrane, the gas fill, and thus the entire pressure accumulator are in order. If the pressure continuously drops to 0 bar within a few seconds without any clearly visible delay in the area of the pre-tension pressure, the bubble reservoir is defective and the pressure

accumulator needs to be replaced. Be sure to observe the maintenance interval IM... (5 years) and the associated maintenance activities at the end of the maintenance instructions.

**AM035** - Replace the breathing filter at the filler neck of the hydraulic fluid tank.

## Orientation



The breathing filter on the oil filler neck of the oil tank must be regularly replaced depending on the ambient conditions.



Due to different requirements and/or specifications of the respective manufacturers, be sure to review the respective manufacturer's documentation!



Filters are hazardous waste and must be disposed of in a controlled manner.

## Requirement

It is essential to keep the filter described here in stock. **It is not permitted to own the machine without this filling and breathing filter.**



Use only the original filters according to the spare or wear parts list.



Only filters with retained particle sizes described in the fluid plans must be used.

## Procedure

1.



Example: Filling and breathing filters of hydraulic and lubrication systems (by ARGO-HYTOS GmbH)

Replace breathing filter.



## AM040 - Check pneumatic system (visual inspection)

## Orientation

Operating fluids such as hydraulic fluids, cooling lubricants, lubricating greases/oils are also subject to degradation or aging as the components involved in this process, and must therefore be serviced, refilled or replaced at regular intervals.

To ensure trouble-free operation, periodic checks of the pneumatic system are necessary.

- Check pressure setting on pressure gauge.
- Check fluid lines.
- Check silencers.
- Drain off condensate.
- Check filters, replace if necessary.



Due to different requirements and/or specifications of the respective manufacturers, be sure to review the respective manufacturer's documentation!

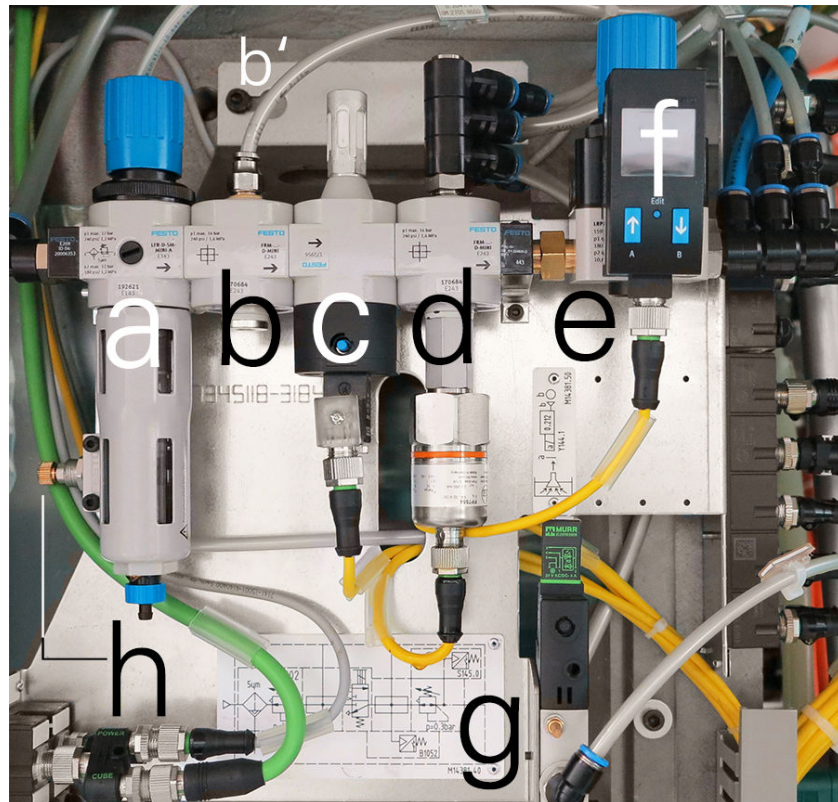

Example: Pneumatic maintenance unit by Festo

- a Filter regulating valve (factory set to 6 bar)
- b Branch module
- b' Branch fire shutter
- c Switch-on valve (electrically operated) with silencer<sup>(\*)</sup>.
- d Branch module with pressure monitoring (factory set to min. 3.0 or 4.0 bar)
- e High-precision pressure regulating valve (factory set to 0.3 bar)
- f Pressure sensor
- g Switching valve for leakage oil extraction
- h Throttle for fire protection sensor
- (\*) Check by manually pushing (using a ballpoint pen or similar) the blue button of the switch-on valve (c)

## Requirement



Power off the machine to depressurize the pneumatic system and secure against accidental switching on.

## Procedure

1. Check fluid lines. Fluid lines must be checked for damage. Pre-damage such as kinks or abrasions should be logged and replacement should be initiated.

2.



Example: Various silencer versions from FESTO

Check silencer, replace if necessary.

3. Drain off condensate.
4. Check filters, replace if necessary.

**AM053** - Checking foldable steps (visual inspection)

## Orientation

The function of the foldable steps must be checked at regular intervals. In particular, all moving parts must be checked for ease of movement. **INDEX** recommends visual inspection, cleaning and any lubrication at the relevant lubrication points once a week.



If grease-dissolving cleaning agents are used when cleaning the steps, the specified lubrication points must be relubricated.

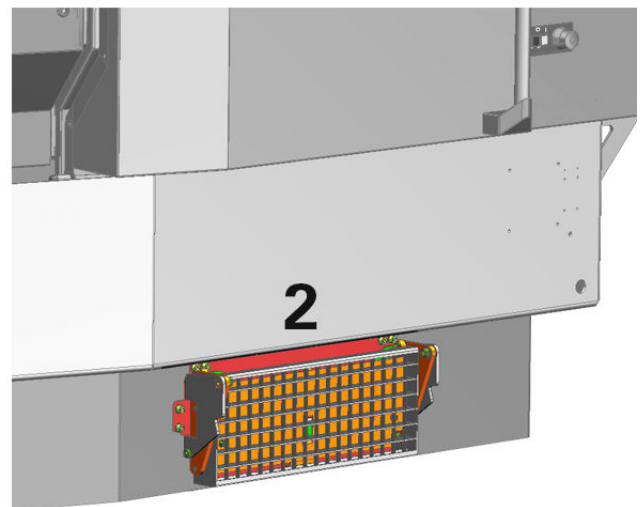
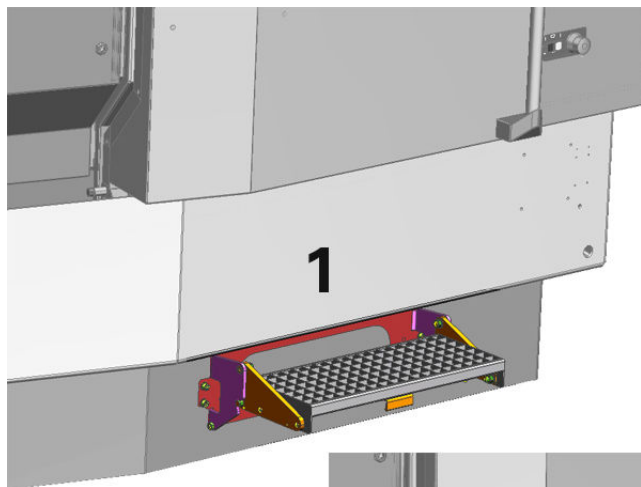

**Example: Step attachment folded out and in**

- 1 Folded out
- 2 Folded in

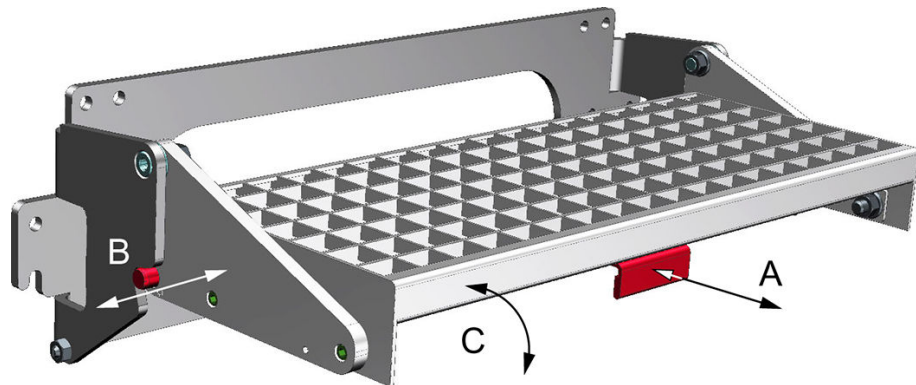

Example: Step folded out - how it works

- A Manual release
- B Locking pin
- C Swivel range



Lubricate at the points marked 1 and 2. **INDEX** uses a multi-purpose paste from Klüber (Klüberpaste 46 MR 401) for assembly

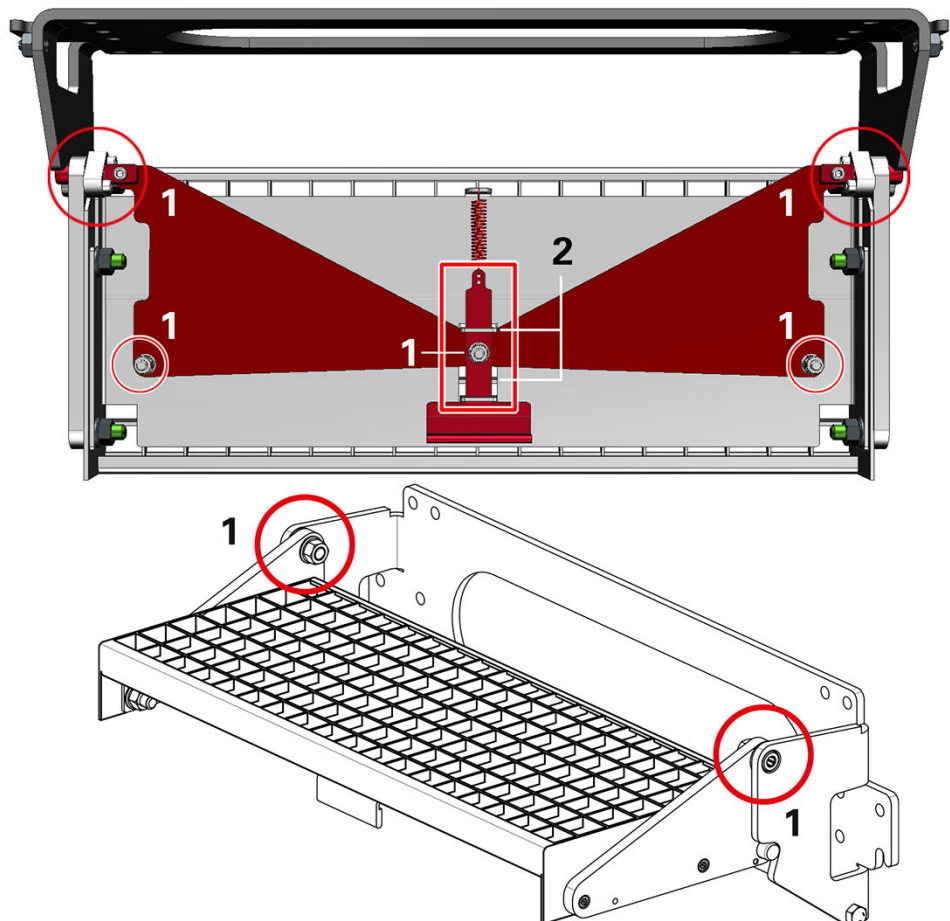

Example of step lubrication points

- 1 Pin joints
- 2 Sheet metal guides of manual release

**Requirement**

A sufficient amount of suitable assembly paste (according to the recommendation or equivalent) must be in stock.

**Procedure**

1.

**Sharp-edged sheets**

Wear personal protective equipment

Clean the step.

2. Lubricate step according to lubrication chart. A brush is suitable for applying the assembly paste to the lubrication points.
3. Check function of the step. Check all moving parts.

## AM055 - Cleaning of the machine

### Orientation

To ensure consistent quality, high availability and value retention, the machine must be regularly cleaned, depending on the operating conditions.

Of course, this is influenced by various factors. The use of emulsion as a cooling lubricant requires a more frequent and intensive cleaning.

Compared to machining producing long chips, machining producing short chips requires a considerably higher maintenance effort. Short chips, such as in the machining of brass or cast iron, form chip accumulations or become deposited in small cracks and corners. These positions must be cleaned regularly to avoid damage to the respective components.

Areas such as rubber seals, sealing lips or wipers are particularly affected points. Frequent cleaning of these areas is particularly important.

### Requirement



Only the agents described in the documentation may be used for the cleaning and after-treatment of the machine.



Example: Suitable tools – chip hooks and chip brush

Always use the proper tool to remove chips.

The following tools are required for cleaning:

- chip hooks,
- chip brushes,
- spray bottles of cleaners or cooling lubricant,
- a sufficient quantity of rags,
- oil to apply to all bare parts by spraying or by brushes.



When cleaning the chip conveyor, vacuum rotation filter and the clean tank, be sure to clean also the corners of the respective containers. Chips and sludge accumulate here, which, for example, immediately contaminate the cooling lubricant when it is replaced. Eventually, this may also lead to damage and thus to a failure of the system.

## Procedure

1.  **Chips and projecting tools in the work area.**  
**Cuts.**  
Use of personal protective equipment such as safety goggles and gloves, and appropriate tools.  
  
Remove chips from the work area.
2. Chip accumulation particularly in the area of the tool carriers and the work area door.
3. Flush work area with cooling lubricant.
4. Wipe clean with rags.
5. Apply an oil film to bare metal plates.
6. Check plates for damage, repair or replace if necessary.
7. Cleaning of chip conveyor, vacuum rotation filter and clean tank. **For these containers/tanks, special attention must be paid to cleaning the respective corners of these containers. Experience has shown that this is where most of the debris settles.**

## AM060 - Swiveling synchronous: Check swivel axes

### Orientation



For the maintenance activities described below, the personnel performing them must have **special expertise in machine operation**.

Hirth couplings are installed on all current **INDEX MS** machines with swivel axes to lock the axis in the working positions. If the swivel axis is not exactly aligned with the tooth gap in the center of the tooth during locking, the corresponding angular error is mechanically overridden during locking. In the process, the mechanical components (locking mechanism and gearbox) are subjected to high loads and therefore wear out more quickly. In addition, the axis motor regulates against this misalignment, whereby the axis current increases, resulting in increased heat input. **Test interval: Every 4 weeks and after collisions.**



Depending on the use of the machine such as: single-shift or multiple-shift operation, the interval may need to be adjusted individually.

To define an individual interval, suitable for the respective machine, a corresponding interval can be created in the maintenance area "**B 1000 Customer area**". Follow the procedure/description in the document "**iXpanel**".

### Requirement



How to perform this check is described in the document "**Swiveling-synchronous - rear machining using the swiveling-synchronous device**" in Section "**Checking swiveling-synchronous**". This document is part of the machine documentation.

### Procedure

1. Check synchronous spindle opposite main spindle and all other positions at which the swivel axis is locked.

If these checks result in a measured value of  $>0.02$  mm (see document Swivel-synchronous - rear.....), the swivel axis must be readjusted.

- 2.



Adjust the swivel axis. **If no training has been given on how to perform this activity, be sure to contact the INDEX service department.**



## AM065 - Check Stäubli robot

## Orientation



Due to different requirements and/or specifications of the respective manufacturers, be sure to review the respective manufacturer's documentation!



Example: MS with robot arm (Stäubli)

## Procedure

1.



Use only the original parts according to the manufacturer's spare or wear parts list!

Failure to observe this warning may result in considerable damage to the robot or the machine.

Perform maintenance according to the manufacturer's instructions.

## AM080 - Clean and lubricate chucks

### Orientation

To ensure reliability and accuracy of the machine, chucks must be subjected to periodic maintenance.

The interval of this maintenance is strongly influenced by the type of material and daily production time. Especially for short chipping materials (e.g., brass or cast iron), these maintenance activities must be performed much more frequently.



Due to different requirements and/or specifications of the respective manufacturers, be sure to review the respective manufacturer's documentation!



Depending on the materials to be machined (e.g.: brass, cast iron) and the number of shifts per day, more frequent cleaning of the chuck is necessary.

For this, the chucks must be removed and completely cleaned.

### Requirement



**Do not use cotton waste for cleaning.**

When cleaning with cotton waste, fibers or thread can get loose causing safety problems.

### Procedure

1.



Caution

**Sharp contours on the clamping device**

**Cuts**

Use personal protective equipment (e.g., protective gloves)

Clean chuck.

2. Lubricate chuck according to manufacturer's instructions.
3. Remove, wash and oil chuck.
4. Clean chuck/collet of synchronous device (if necessary completely remove) and lubricate (observe the manufacturer's instructions).

## AM095 - Check work area light (visual inspection)

### Orientation

To ensure even illumination of the working areas in the machine, work area lights are installed in the work area.

These enable safe working and must therefore be checked regularly. **Maintenance and repair work on damaged lamps may only be carried out by a qualified electrician or must be checked by the manufacturer or replaced immediately.**

### Requirement



Service and maintenance are to be carried out according to the manufacturer's specifications.

### Procedure

1.



For extended periods of downtime or maintenance time, cleaning of the light surfaces is recommended. This prevents premature clouding of the light surfaces.

Clean light surfaces. Only use a cloth soaked in normal household detergent.

2. Check all lamps (visual inspection).

3.



Example: Work lamp MTAL 4 S (Waldmann)\*



**Example: Work lamp MACH LED PLUS MLAL 57 S (Waldmann)\***

\* Due to design or technical changes, illustrations in this document may differ from the delivered product.

Check the lamps for damage. If cooling lubricant has already penetrated into the work area light, the lamp must be replaced.

## AM100 - Clean cooling lubricant outlet on spindle carrier

### Orientation

If the cooling lubricant outlet is blocked on the spindle carrier, excess cooling lubricant can no longer drain from the space behind the spindle carrier cover.



To avoid resulting damage to the machine, the cooling lubricant outlet must be cleaned regularly.



If debris (chips) is clearly visible behind the blanking plug (7), the area behind the spindle cover must be cleaned. To carry out this activity, you must contact the **INDEX** hotline, **INDEX** Service or an **INDEX** representative.

### Procedure

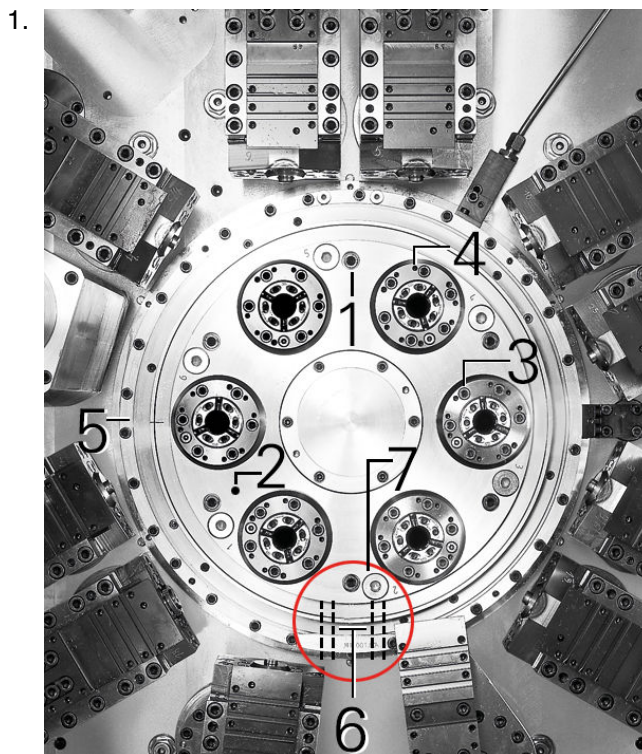

Example: Spindle carrier cover with cooling lubricant outlet MS22-6

- 1 Mounting screws for spindle carrier cover
- 2 Spindle carrier cover
- 3 Mounting screws for clamping element holder
- 4 Jacking screws M5/M6
- 5 Housing
- 6 Drain holes
- 7 Blanking plug

Remove blanking plug (7). Always remove the bottom blanking plug (7) depending on the position of the spindle drum.

2. Inject oil through the hole (7) in the spindle carrier cover (2). This oil should soon exit from the drain holes (6). **If the injected oil does not soon exit from the drain holes, the drain holes must be cleaned.**

3.



The area around the drain holes (6) may have a different design depending on the machine type or design of the machine. Various panels or covers may have to be removed.

Clean drain holes (6).

4. Repeat the process until the injected oil freely flows out of the drain holes.
5. Replace the blanking plug (7) and reinstall any removed panels or covers.

**AM110** - Check the window pane at the level sensor of the vacuum rotation filter

## Orientation

Check the window pane at the level sensor of the vacuum rotation filter. This sensor is located at the outside of the vacuum rotation filter (see Figure 1). The sensor monitors the fill level in the cooling lubricant tank. A very dirty window pane may cause malfunction. Therefore, regular visual inspection from the outside is necessary. If the Window pane is very dirty, it must be cleaned on the inside.

## Procedure

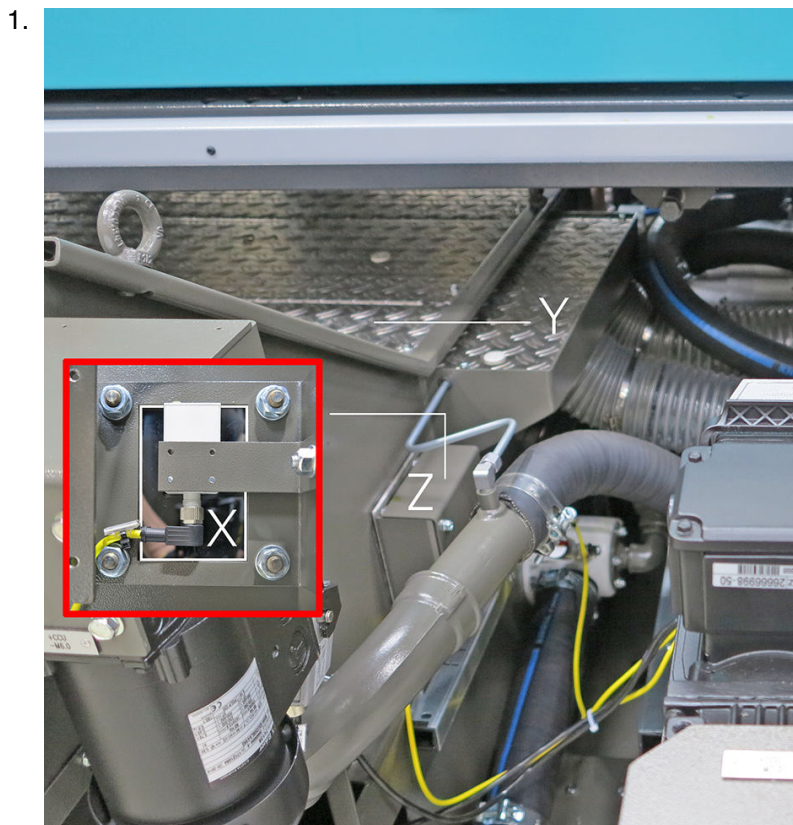

**Figure 1: Location of the level sensor on the vacuum rotation filter**

- X Inspection window
- Y Cover plate
- Z Cover of the sensor

Check the window pane at the level sensor of the vacuum rotation filter.

2. Unscrew the cover (Z).
3. Check the window pane on the sensor.

**Alternatively, the following procedure can be used!**

If the window pane is very dirty, the pane must be cleaned on the inside of the cooling lubricant tank.

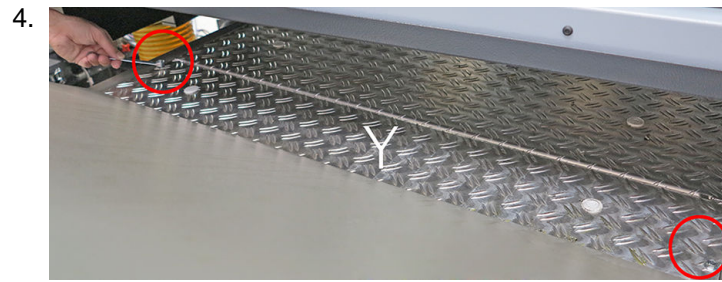

Figure 2: Cover (Y) of the vacuum rotation filter

Unscrew and remove the cover (Y).

5.  Wipe the window pane (1) on the inside carefully with a soft cloth. **Make sure that no debris such as chips or the like adhere to the rags or paper towels, which may scratch the window pane.**



Figure 3: Window pane on the sensor (view from inside)

Reattach cover (Y) and fasten with screws.



## AM123 - Checking the coolant - option 1

## Orientation

For add-on equipment that cannot be cooled conventionally with cooling lubricants or hydraulic fluid due to high temperature development, separate cooling is provided in an independent cooling circuit. The coolant used here must be checked continuously for its condition like other coolants.

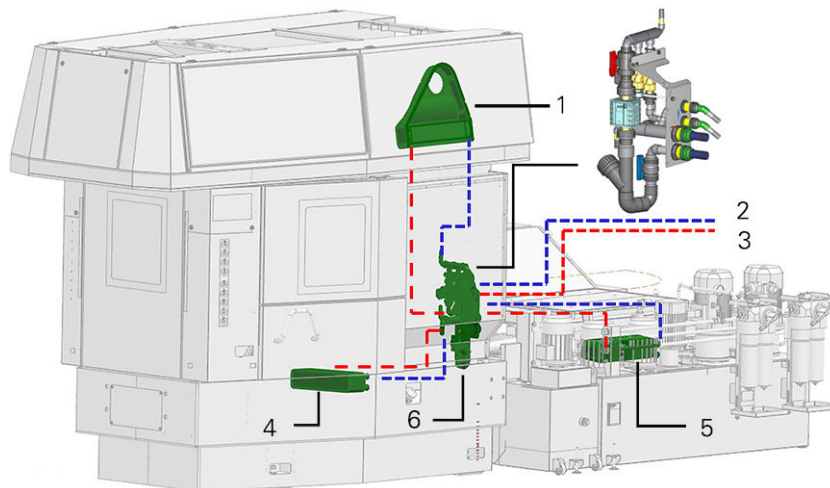

Example: Cooling diagram of MS

- 1 Control cabinet cooling
- 2 "Cold" circuit
- 3 "Warm" circuit
- 4 Heat exchanger machine
- 5 Heat exchanger cooling lubricant
- 6 Cooling water distribution unit

The system comprises a cooling circuit on the machine side and either

1. a water recoler located next to the machine or
2. an external cooling circuit provided by the machine operator/owner.



Due to different requirements and/or specifications of the respective manufacturers, be sure to review the respective manufacturer's documentation!



For all work in connection with operating materials, the information in the data sheets of the operating fluid manufacturers and the information in the documents **Notes on Operating Materials** and **Transport, Installation, Commissioning** must be observed.

## Requirement



When using a water recoler, be sure to follow the manufacturer's instructions.

## Procedure

1. Check coolant.
2. Check fluid lines for damage such as buckling and abrasions, and for liquid leaks. If necessary, replace fluid lines. Record the age or date of replacement of fluid lines in the service, testing and maintenance schedules or reports.

3.

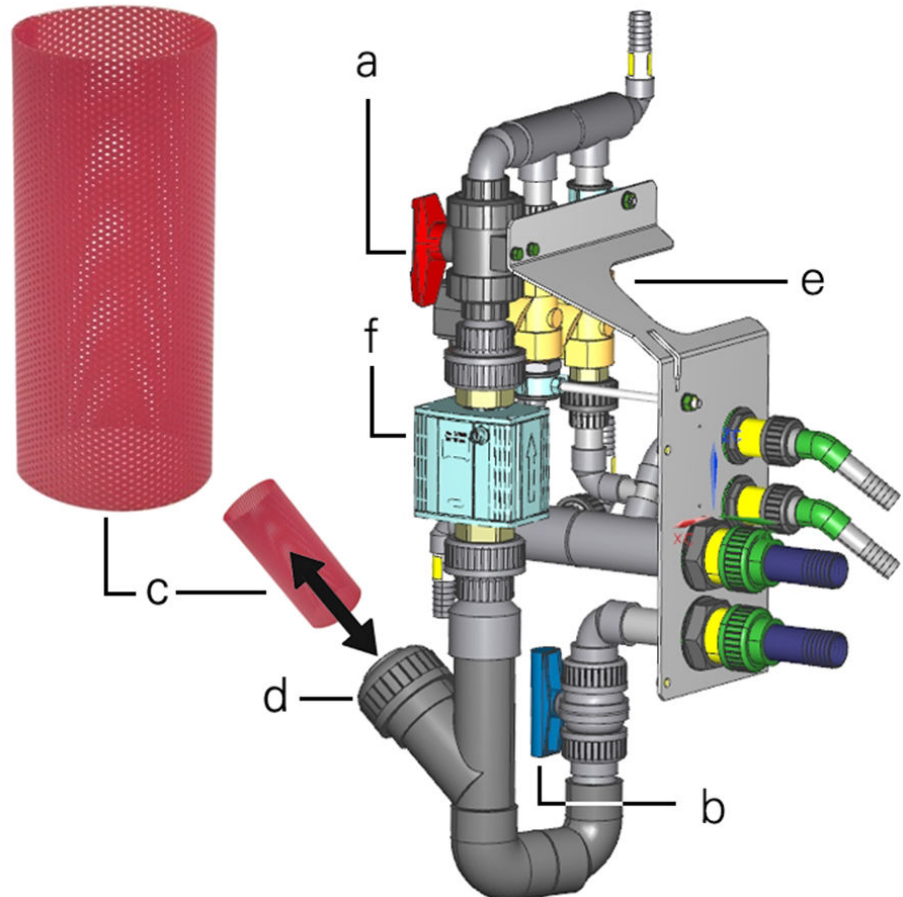

**Example: Cooling water distribution unit with screen pipe (GF Piping Systems)**

- a Shut-off valve 1
- b Shut-off valve 2
- c Screen pipe (made of plastic or metal depending on design/variant)
- d Filter cover
- e Valves
- f Flow monitor

Check the filter in the cooling water distribution unit. Close the two shut-off valves (a and b). Open the filter cover and remove the screen pipe (c). Clean the screen pipe or replace if necessary and refit. Close the filter cover again and reopen the shut-off valves.

4. Check water temperature and flow rate of cooling water (sensor system).

## AM125 - Checking the coolant - option 2

## Orientation

For add-on equipment that cannot be cooled conventionally with cooling lubricants or hydraulic fluid due to high temperature development, separate cooling is provided in an independent cooling circuit. The coolant used here must be checked continuously for its condition like other coolants.

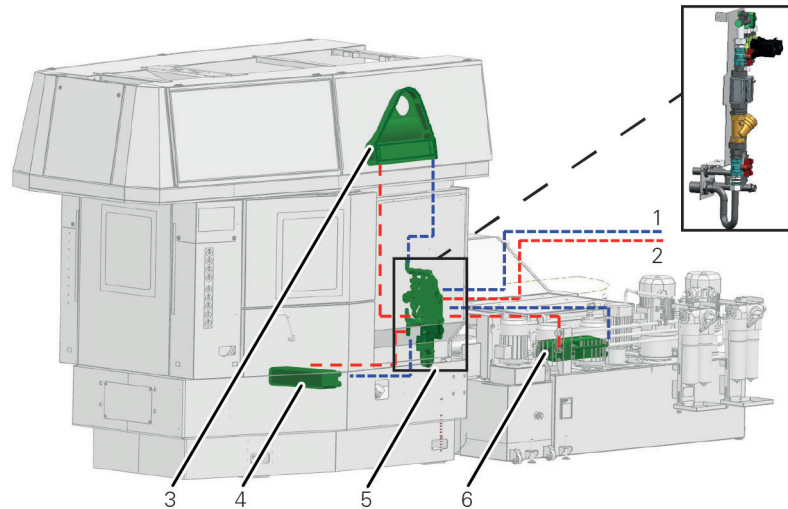

Example: Cooling diagram of MS

- 1 "Cold" circuit
- 2 "Warm" circuit
- 3 Control cabinet cooling
- 4 Heat exchanger machine
- 5 Cooling water distribution unit
- 6 Heat exchanger cooling lubricant

The system comprises a cooling circuit on the machine side and either

1. a water re cooler located next to the machine or
2. an external cooling circuit provided by the machine operator/owner.



Due to different requirements and/or specifications of the respective manufacturers, be sure to review the respective manufacturer's documentation!



For all work in connection with operating materials, the information in the data sheets of the operating fluid manufacturers and the information in the documents **Notes on Operating Materials** and **Transport, Installation, Commissioning** must be observed.

## Requirement



When using a water re cooler, be sure to follow the manufacturer's instructions.

## Procedure

1. Check coolant.
2. Check fluid lines for damage such as buckling and abrasions, and for liquid leaks. If necessary, replace fluid lines. Record the age or date of replacement of fluid lines in the service, testing and maintenance schedules or reports.

3.

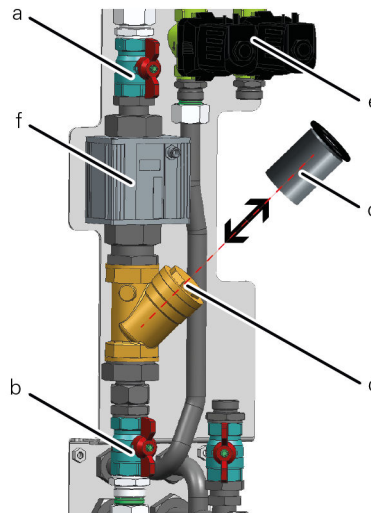

**Example: Cooling water distribution unit MS24-6/ MS32-6.3**

- a Shut-off valve 1
- b Shut-off valve 2
- c Filter insert with O-ring
- d Filter cover
- e Valves
- f Flow monitor

Check the filter in the cooling water distribution unit. Close the two shut-off valves. Open the filter cover and remove the filter insert. Clean the filter insert or replace if necessary and refit. Close the filter cover again and reopen the shut-off valves.

4. Check water temperature and flow rate of cooling water (sensor system).

## AM138 - Removing clamping element holder

### Orientation



Due to different requirements and/or specifications of the respective manufacturers, be sure to review the respective manufacturer's documentation!



The removal tool described below refers to the use of standard collet clamping. Removal of the clamping element holder is necessary as part of regular cleaning of the machine. In order to support removal that is easier on the bearings, **INDEX** requires the use of a removal tool for removing the clamping element holder for standard collet clamping.



**To avoid putting strain on the spindle bearings, it should generally be possible to remove each clamping device in a way that is easy on the bearings without using a rebound hammer (Zocker). Therefore, forcing pins or removal tools must be provided for all clamping devices.**

### Procedure

1. Loosen and remove mounting screws of clamping element holder.

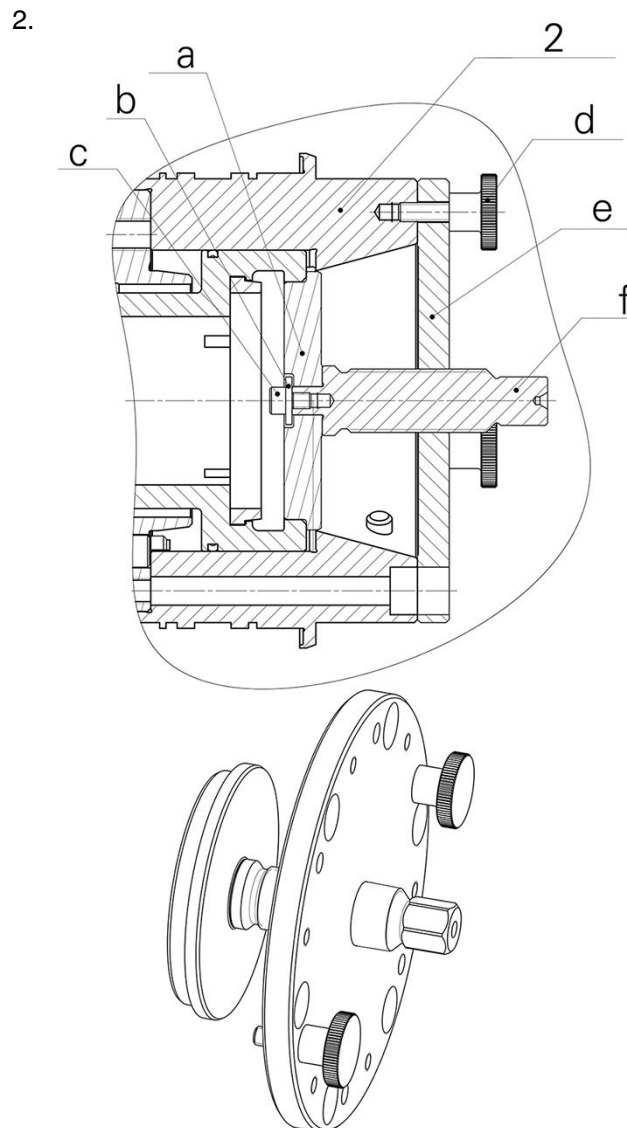

**Removal tool for dismantling the clamping element holder for standard collet clamping**

- 1 -
- 2 Clamping element holder
- a Thrust block
- b Washer
- c Cyl. head screw
- d Knurled screw
- e Pane
- f Threaded spindle

Removing the clamping element holder with removal tool. Select the respective thrust block **(a)** and screw it to the removal tool. Then mount the removal tool to the clamping element holder using the 3 knurled screws **(d)**.

3.

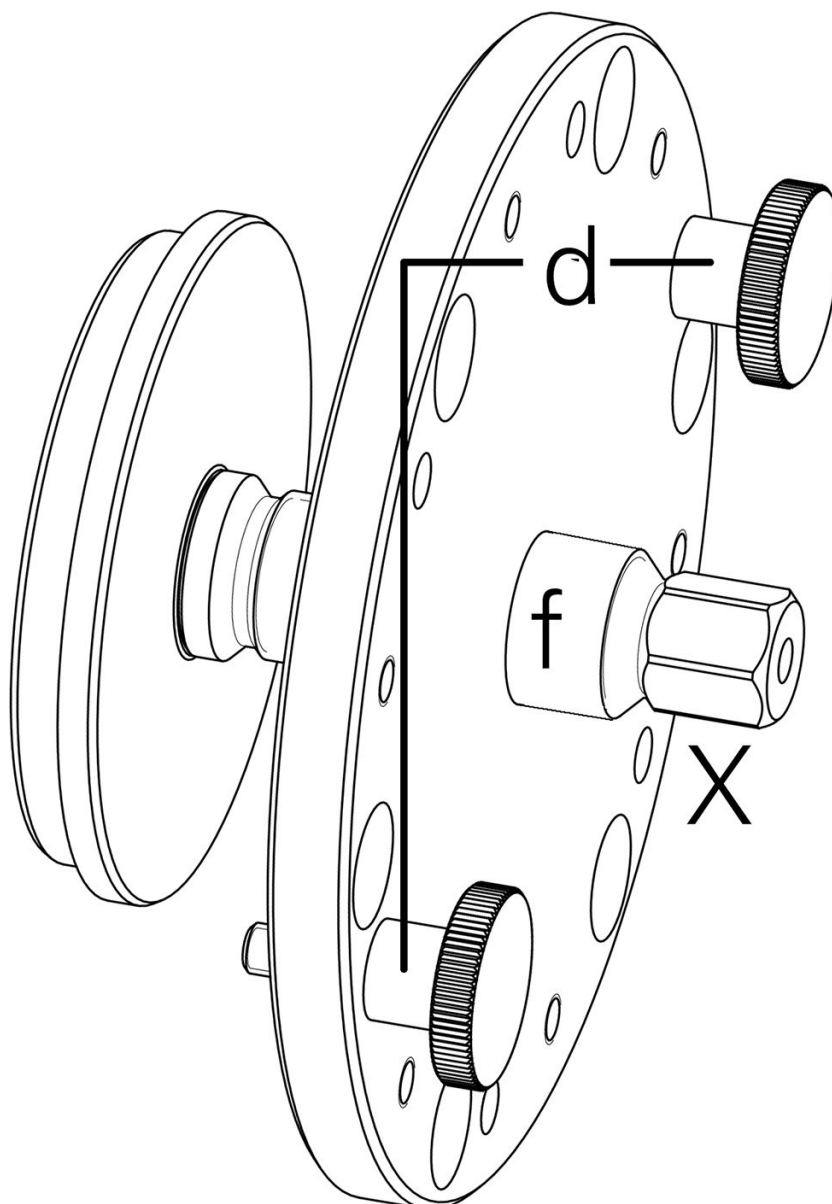
**Removal tool for clamping element holder MS52**

- d Knurled screw
- f Threaded spindle
- X Hexagon

Turn the hexagon (**X**) on the threaded spindle (**f**) until the clamping element holder is removed.

4. Clean clamping element holder.
5. After cleaning, reassemble the clamping element holder. Insert cyl. head screws (6x) and tighten them crosswise in 2 steps. In the 1st step to a tightening torque of 15 Nm. In the 2nd step to 36 Nm.

## AM240 - Locking the spindle



Carrying out the maintenance activities described below requires special knowledge. For this reason, these maintenance activities must only be carried out by staff that has received adequate training by the machine manufacturer!

### Orientation

This is not a maintenance activity in the strict sense. For carrying out some maintenance activities, e.g., **“Lubricate clamping devices”** or **“Clean collets and base body”**, this procedure is absolutely useful.

### Requirement

To prepare the spindles for certain activities, they must be locked. Machine-specific aids are available for this purpose. In this case, lock the spindle with a pin (see example) so that spindle rotation is no longer possible. These devices are components of the machine and are included with the accessories.

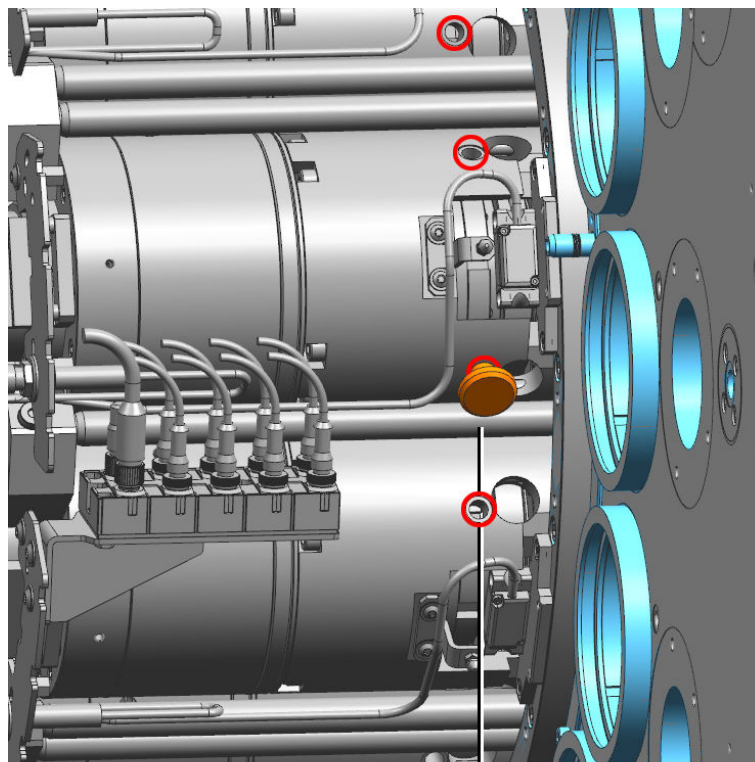

Example: Spindle lock MS32-6.2 MS32-6.3 MS40-6 MS40-8 MS52-6.3



## Procedure

1. Deactivate spindle control on the machine controller.

2.



Caution

**Mounting in adjacent holes will damage the encoder system of the respective spindle, requiring repair and readjustment.**

Always make be sure to mount the locking pin only at the points/holes marked in red on the respective spindle.

Turn the spindles by hand until the locking pin can be mounted.

3. **Be sure to remove the spindle lock (device/locking pin) after finishing the work.**

## AM320 - Clean collets and base body



Carrying out the maintenance activities described below requires special knowledge. For this reason, these maintenance activities must only be carried out by staff that has received adequate training by the machine manufacturer!

### Orientation

The Hainbuch ZW clamping system is used on this lathe. This clamping system is suitable for square, hexagonal and bar stock. The collets and collet mountings must be cleaned regularly depending on the machine utilization, the type of machining, and the materials used. Hainbuch offers various tools for removal and installation.

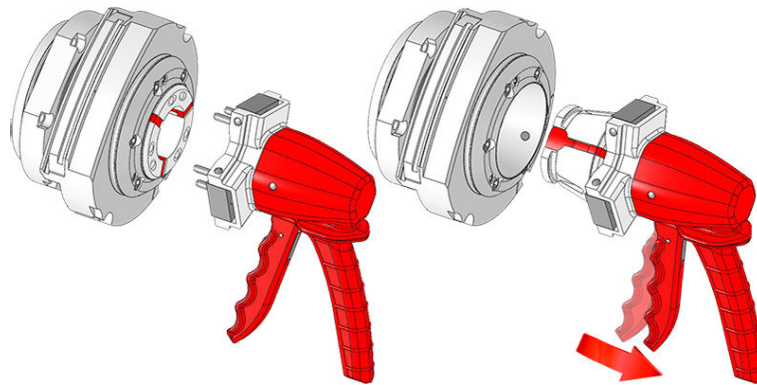

Example: Removing collet (Hainbuch)



Example: Manual changing device (Hainbuch)

## Requirement



Due to different requirements and/or specifications of the respective manufacturers, be sure to review the respective manufacturer's documentation!

To clean the collets, sufficient quantities of cleaning agent such as benzine as well as grease (oil-resistant) for greasing the collets are necessary. For the operating materials to be used, see the manufacturer's documentation and the document "Information on operating materials".



When the machine is switched on, the spindle is electronically controlled (spindle control) as standard, even when the work area door is open. The rotary position is maintained for active torques up to the maximum motor torque. If screw connections are tightened or loosened on the clamping device, the tightening or loosening torque is supported by the motor torque. For many activities, mechanical locking of the spindle according to "AM... Lock spindles" can therefore be omitted.

If no mechanical locking is provided, however, it must always be expected that the spindle will go out of control and suddenly no supporting motor torque is applied if the torque load is too high. Tools and working position must therefore always be selected such that there is no danger to the operator or machine if the spindle control suddenly shuts off. If high torques are already expected to be applied, the spindle must be mechanically locked immediately.

To do so, be sure to follow the "**AM... Lock spindles**" maintenance activity.

## Procedure

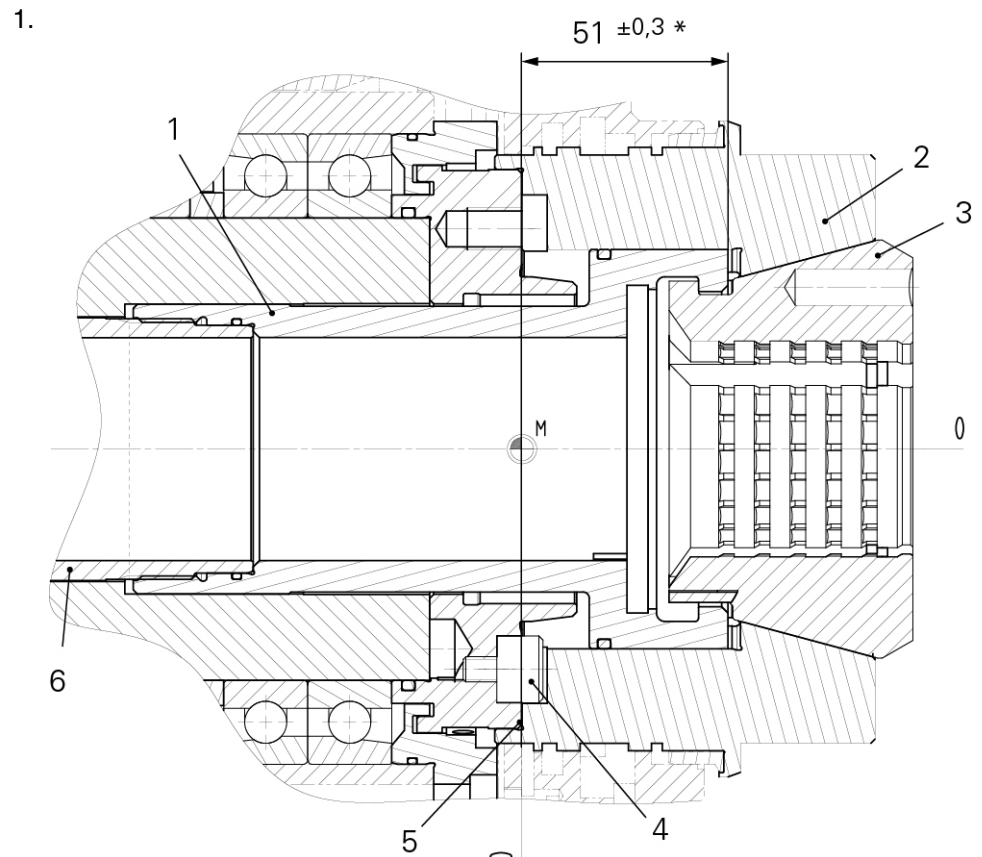

**Example: Clamping system MS52-6.3 (Hainbuch)**

- 1 Base body – bonded to the clamping tube
- 2 Clamping element holder
- 3 Collet
- 4 Anti-twist lock
- 5 Spindle nose end face
- 6 Clamping tube
- \* (Installation dimension in "Clamp open" position)

Remove collet (3) using the changing device. Remove 6 screws and remove clamping element holder (2). See also AM... Removing clamping element holder.

- 2.
- 

Base body (1) and clamping tube (6) are bonded together.  
**(LOCTITE®)**



**Example: Installation tool (Hainbuch)**

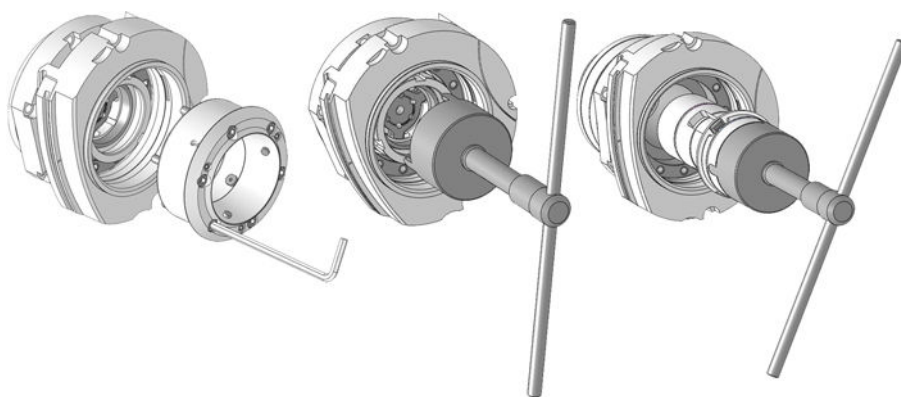

**Example: Remove clamping element holder and base body**

Remove the base body (1) and clamping tube (6) using the installation tool, and clean.

3. Check clamping tube (6), base body (1), and Glyd Rings® for damage and wear, replace if necessary.
4. Clean clamping element holder (2) and collet (3). Grease collet (oil-resistant grease).
5. Reinstall base body (1) and clamping tube (6). Grease the base body (1) and clamping tube/thread (6) according to the manufacturer's instructions and screw them back into the spindle using the installation tool.

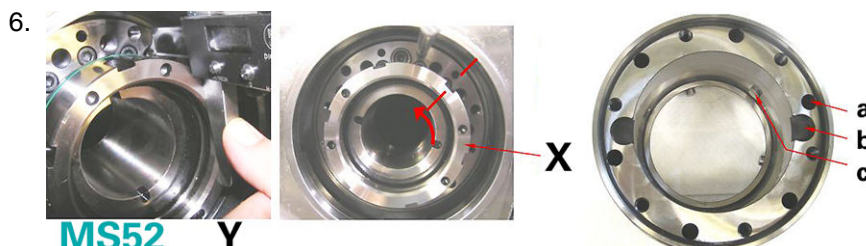

**Example: Position of base body MS52**

- a Hole for auxiliary screw
- b Hole for driver
- c Base body fixation
- X Base body position
- Y Measure installation dimension from base body to spindle nose

Check installation dimension. Check the installation dimension between the spindle nose end face (5) and the base body (1) against the size  $51^{\pm 0,3}$  mm (in "Clamp open" position). If the installation dimension is not correct, turn the base body forward and backward, until the setting dimension is achieved. Observe the installation position (X).

7. Place the clamping element holder (2) on the spindle nose face (5) and screw in 6 screws.
8. Tighten screws. Tighten the screws crosswise to a torque of 36 Nm.
9. Check radial runout. If the specified tolerance of  $<15 \mu\text{m}$  cannot be achieved, the spindle mount must be removed again and reassembled offset by one thread. Check radial runout again, repeat the procedure if necessary.
10. Insert collet (3).
11. **Be sure to remove the spindle lock (device/locking pin) after finishing the work.**

**AM337** - Remove, inspect, lean and reinstall the spindle liner tubes

Carrying out the maintenance activities described below requires special knowledge. For this reason, these maintenance activities must only be carried out by staff that has received adequate training by the machine manufacturer!

## Orientation



**Always grease the spindle liner tubes before reinstalling them. Only heat-resistant greases may be used.**

The spindle liner tubes must be periodically removed and inspected. Chips in the clamping tube may damage the spindle liner tubes. Hainbuch offers various tools for removal and installation.



Example: Manual changing device (Hainbuch)

## Procedure

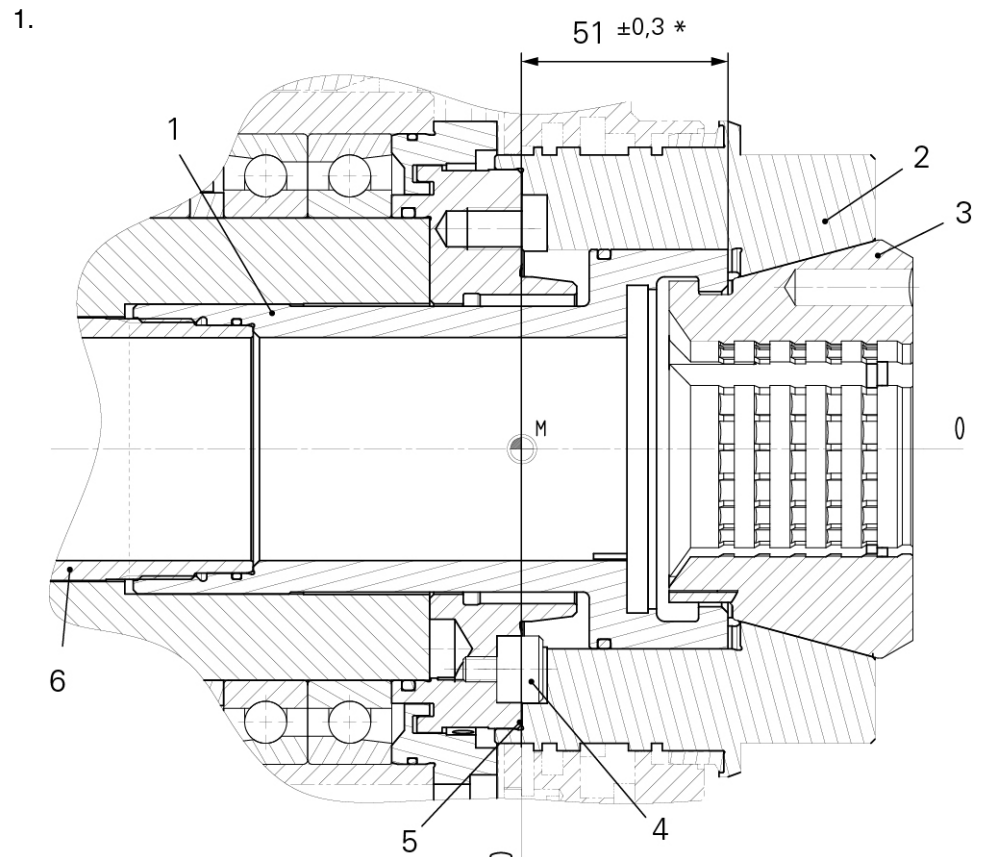

**Example: Clamping system MS52 (Hainbuch)**

- 1 Base body – bonded to the clamping tube
- 2 Clamping element holder
- 3 Collet
- 4 Anti-twist lock
- 5 Spindle nose end face
- 6 Clamping tube
- \* (Installation dimension in "Clamp open" position)

Remove spindle liner tubes.



2. Remove collet using the changing device.
3. Pull out the spindle liner tube towards the work area.
4. Clean spindle liner tubes and lubricate with heat-resistant grease.
5. Before reinserting the spindle liner tube, make sure that the clamping tube is free of chips.
6. Reinstall the spindle liner tube in the spindle.
7. Reinsert the collet using the changing device.



**AM340 - Visual inspection of the fire extinguishing system**

**Orientation**

The fire extinguishing system must only be inspected directly by the manufacturer of the extinguishing system or by a person authorized by the manufacturer.

-  **The fire extinguishing system is still active even when the machine is switched off!**
-  **Flash photography in the immediate vicinity of the sensors may trigger the fire extinguishing system.**

**Procedure**

1. Be sure to follow the manufacturer's documentation.
- 2.

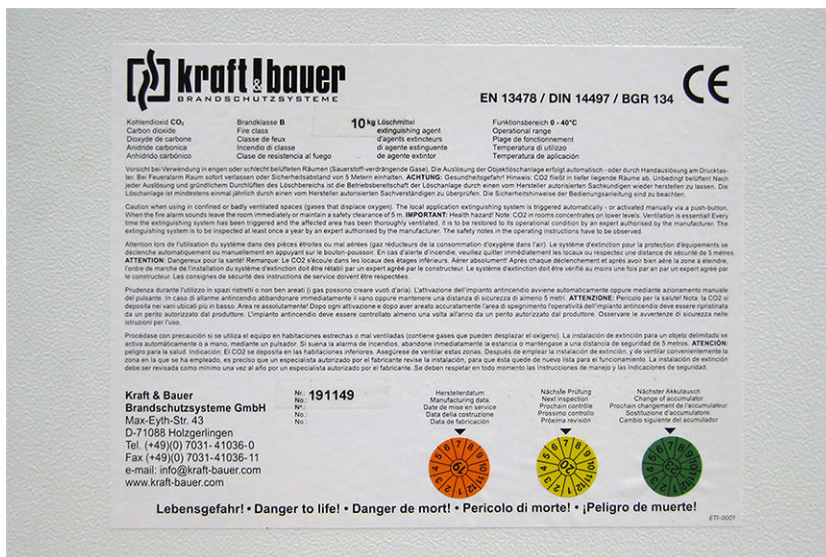

**Example: Inspection stickers Kraft & Bauer**

3. Check sticker for manufacturing date.
4. Check sticker for inspection date.
5. Log all work carried out in the service, inspection and maintenance schedules/ logs of the customer and the manufacturer.

## AM370 - Check gas springs on the control cabinet door, replace if necessary

### Orientation

To carry out work on the control cabinet of multi-spindle lathes, the cabinet doors are fitted with gas springs. These gas springs facilitate opening the heavy cabinet doors. In addition, they retain the cabinet doors in the upper position, thereby allowing safe working in the control cabinet. The options for checking the door are simple and can be carried out in a minimum of time.

### Requirement



Working with ladders



**The suitable ladders or platforms for this purpose must be secured to the eyelets provided in the control cabinet (see figures – Working with ladders).**

Additional eyelets can be screwed in, in the region of the control cabinet. Various screw-in points are provided for this, depending on the machine type.

### Procedure

1. Check the cabinet door when opening. If the cabinet doors can be opened without too much effort, it can be assumed that the doors or the gas springs are in order. If, however, the door greatly distorts when opening, this is a sign that one of the two gas springs is defective and must be replaced.

2.



Example: Gas pressure damper (ACE)

Check gas springs. In the second step, the condition of the gas springs should be inspected after opening the door. If one of the gas springs is highly wet, it must be replaced. In case of heavy soiling (depending on the environment), dirt adhering to the gas spring may embed into the seals, thereby damaging the piston rod and seals. Over time this leads to malfunction of the gas springs.

3.

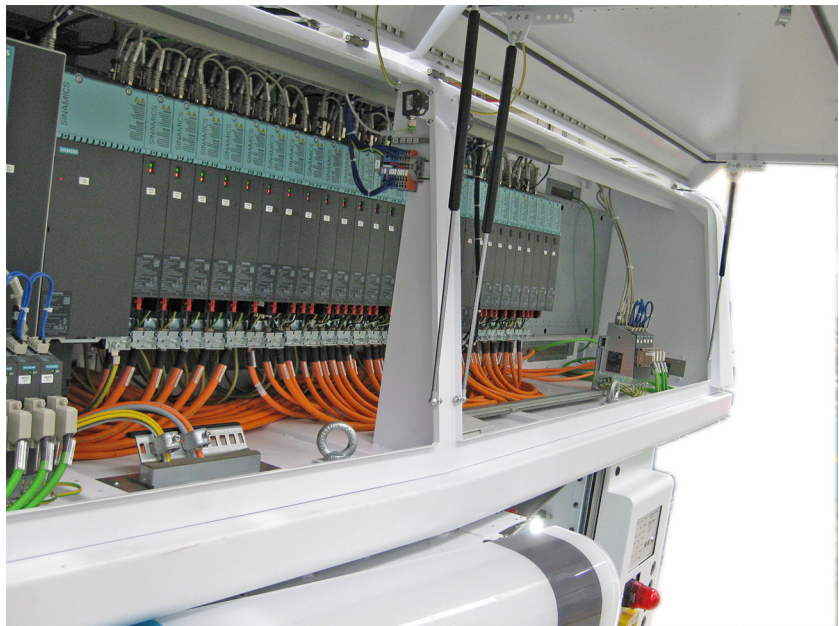

Example: Cabinet doors on a multi-spindle lathe

Checking the door after opening. Another test is that after opening the door and reaching the end position, the door should be horizontal and parallel to the machine. If the door bends on one side or even leaves its Open position, both gas springs or only the defective gas spring needs to be replaced.

4. Replace gas spring. If a gas spring needs to be replaced, be sure to read the manufacturer documentation. When installing the new gas spring, make sure that the installation position (flush) is oriented in the moving direction of the control cabinet door. Improper installation may cause immediate destruction of the new gas spring, such as bending or kinking.

**Service Interval - 1.000 Operating hours**

## Maintenance Summary - 1.000 Operating hours



It is recommended to document the maintenance activities carried out by using the appropriate maintenance log. The maintenance log has the document number DIM028EN - 25.03.2024.

**BM010** - Customer area

**BM010** - Customer area

## Orientation

This area of the maintenance **B** for **1000 h** is generally empty when the machine is delivered. This area is freely editable and is used by the customer to create their own maintenance activities/intervals or work.

For example:

- Interval for cleaning the work area and chip conveyor due to heavy contamination/chip accumulation from short-chipping materials.
- Interval for a filter change.
- Interval for testing the cooling lubricant.

Maintenance contents from the user documentation of additionally purchased peripheral devices that were **not** obtained from **INDEX** can also be transferred to this area.



The procedure for creating your own individual maintenance intervals/contents is described in the **iXpanel** document. This document is both the contents of the user documentation (in paper form) and can be found on the supplied data carriers in Chapter 1 "Instructions".

## Procedure

1. Acknowledgment of maintenance activities **B 1000 h**.





**Service Interval - 2.000 Operating hours**

## Maintenance Summary - 2.000 Operating hours



It is recommended to document the maintenance activities carried out by using the appropriate maintenance log. The maintenance log has the document number DIM028EN - 25.03.2024.

- CM010** - Checking the inspection and maintenance schedules/logs
- CM030** - Check hydraulic system
- CM046** - Replace hydraulic fluid filters
- CM048** - Replacing the hydrostatic filter
- CM052** - Fluid cooling - oil filters for heat exchangers, spindle carriers and synchronizers
- CM060** - Check pre-pressure of pressure accumulators
- CM080** - Inspection of water cooling equipment (option)
- CM140** - Inspection of the pneumatic system
- CM180** - Checking the window pane
- CM270** - Check MS guard switch/interlock
- CM290** - Check IEMCA loading and unloading system
- CM330** - Check gas springs on the control cabinet door, replace if necessary
- CM480** - Check operating panel for general condition

**CM010** - Checking the inspection and maintenance schedules/logs

Carrying out the maintenance activities described below requires special knowledge. For this reason, these maintenance activities must be carried out only by authorized personnel of the manufacturer!

## Orientation

Before starting any maintenance activities, the customer's documentation (inspection and maintenance schedules / logs) must be checked for any maintenance activities performed. Any inspection and maintenance schedules/logs are used for problem tracking and are important for documentation and implementation of warranty claims.

## Requirement



Compliance with and implementation of the inspection and maintenance schedules/logs increases process capability and the life of the **INDEX** turning and machining center.

## Procedure

1.



Caution

**Machine that has not been maintained and serviced.  
Shorter life of the machine, lower process capability.  
Failure to comply with the inspection and maintenance  
schedules/logs.**

**Reduced process capability and availability of the machine**

Check compliance with the inspection and maintenance schedules, and customer documentation regarding performed maintenance activities (inspection and maintenance schedules/ logs)

Have inspection and maintenance schedules/logs been created and have the maintenance steps mentioned been carried out.

## CM030 - Check hydraulic system



Carrying out the maintenance activities described below requires special knowledge. For this reason, these maintenance activities must be carried out only by authorized personnel of the manufacturer!

### Orientation



To check the settings of the various components, they can be made visible in the control system in the **Sensor System** area. Refer to the section on the sensor system in the documentation **Operating the Machine**.

Operating fluids such as hydraulic fluids, cooling lubricants, lubricating greases/oils are also subject to degradation or aging, and must therefore be serviced, refilled or replaced at regular intervals. The hydraulic fluid must be changed periodically to ensure reliable operation of the machine. Review of the maintenance and service logs.

### Requirement

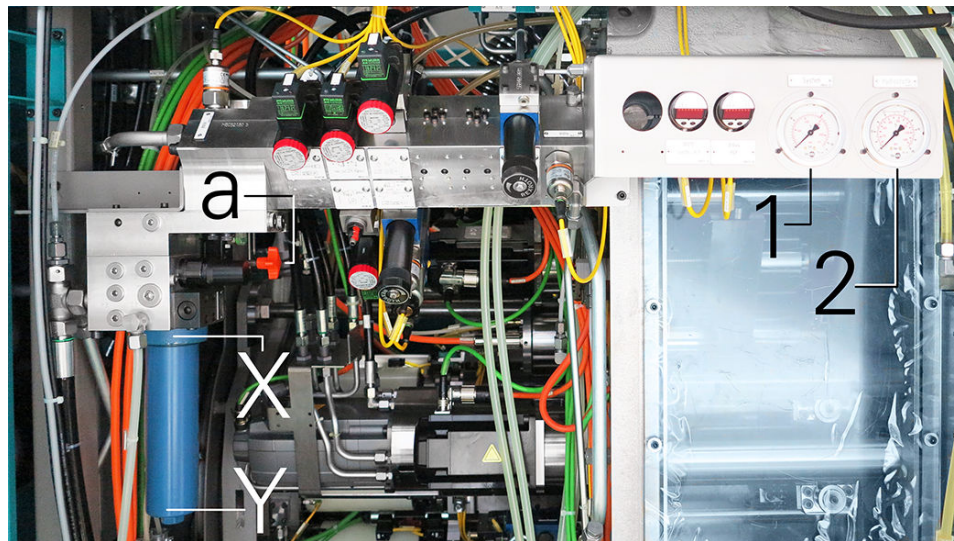

Example: Hydraulic unit MS52-6.3

- a Accumulator drain valve
- 1 Pressure gauge for system pressure
- 2 Hydrostatic pressure gauge
- X Hydraulic fluid filter
- Y Filter bowl

The maintenance of the hydraulic system requires the following auxiliary or working equipment:

- servicing, testing and maintenance schedules/logs of the customer.
- Use an ample supply of cleaning rags - **no cotton waste**.
- A sufficient amount of hydraulic fluid for refilling/changing. - **Hydraulic fluid, specification and quantity as specified in the technical data.**
- Hydraulic fluid filter, main and bypass filter. - **Use only original filters.**
- Various sizes of jaw and box wrenches, and Allen keys.



For all work in connection with operating fluids, the information in the data sheets of the respective manufacturers and the information in the document **Information on operating fluids** must be followed.



Only filters with retained particle sizes described in the fluid plans must be used.



Depressurize the hydraulic system by opening the accumulator drain valve, turn off the machine and prevent it from restarting.



Use personal protective equipment, e.g., suitable safety gloves and safety goggles, when working in tanks with hydraulic fluids. Contaminated or degraded hydraulic fluids are hazardous waste and must be disposed of according to regulations. Also clean the hydraulic fluid tank before filling in new hydraulic fluid. When changing the type of hydraulic fluid, the unit must be flushed with new fluid.



**Do not use cotton waste for cleaning.**

When cleaning with cotton waste, fibers or thread can get loose causing safety problems.

The following tools are required:

- A pump with pre-filter is required for changing the hydraulic fluid. - **Filter fineness 3 µm (β200)**
- Hydraulic fluid, specification and quantity as specified in the technical data
- Empty oil drum or similar for collecting the used oil
- Cleaning rags. - **Do not use cotton waste**
- Personal protective equipment

During maintenance of the entire hydraulic system, first perform a visual inspection of all hydraulic components for leakage and their visual condition. The following components must be examined during maintenance of the hydraulic system:

- Hydraulic fluid filter (replace the filter cartridge of the hydraulic fluid filter, if necessary )
- Hydraulic pump
- Pressure gauges
- Pressure relief valves and directional control valves
- Safety valves
- Fluid lines
- Check oil level in the sight glass of the hydraulic fluid tank

## Procedure

1. Check all hydraulic blocks, distributors, valves, and pumps for leaks and function.
2. Check hydraulic system pressure and related sensors (sensor system).

3. Check lubrication pressure and related sensors.
4. Check clamping pressure on main spindle side and related sensors.
5. Check clamping pressure on synchronous side and related sensors.
6. Check hydrostatic pressure and related sensors.
7. Check hydraulic temperature and related sensors.
8. Check cooling lubricant temperature and related sensors (sensor system).
9. Check water temperature, water filter, and fill level using the corresponding sensors (sensor system).
10. Check water filter (cooling water) and related sensors.
11. Check water flow and related sensors.
12. Check main flow filter (system pressure) and related sensors (sensor system), replace if necessary.
13. Check bypass filter (hydrostatic system) and related sensors (sensor system), replace if necessary.
14. Replace oil filter (fluid filter for cooling).
15. Pressure relief valves – test function and check TÜV seal.
16. Check hydrostatic pump.
17. Check quill guide for leaks.
18. Check condition of the hydraulic fluid (visually/sight glass).
19. Visual inspection for leaks.
20. Check fluid lines for damage such as buckling and abrasions, and for liquid leaks. If necessary, replace fluid lines. Record the age or date of replacement of the fluid lines. Enter in the customer's service, inspection and maintenance schedules.
21. Clean hydraulic fluid and hydraulic fluid tank. **This activity is not part of maintenance by INDEX personnel. This activity is to be performed by the customer.**

## CM046 - Replace hydraulic fluid filters



Carrying out the maintenance activities described below requires special knowledge. For this reason, these maintenance activities must only be carried out by staff that has received adequate training by the machine manufacturer!

### Orientation

One or more hydraulic fluid filters are installed on the machine depending on the product and its equipment. The filters are provided with a sensor that signals malfunction or contamination to the control. If a fault is displayed on the control, the filter unit should be removed or replaced.



For all work in connection with operating fluids, the information in the data sheets of the respective manufacturers and the information in the document **Information on operating fluids** must be followed.

### Requirement



Only filters with retained particle sizes described in the fluid plans must be used.



Use only the original filters according to the spare or wear parts list.

A suitable container should be ready for the disposal of the filter and the residual oil in the filter bowl.

### Procedure

1.



Power off the machine, depressurize the hydraulic system by opening the accumulator relief valve(s), and protect against accidental power on.

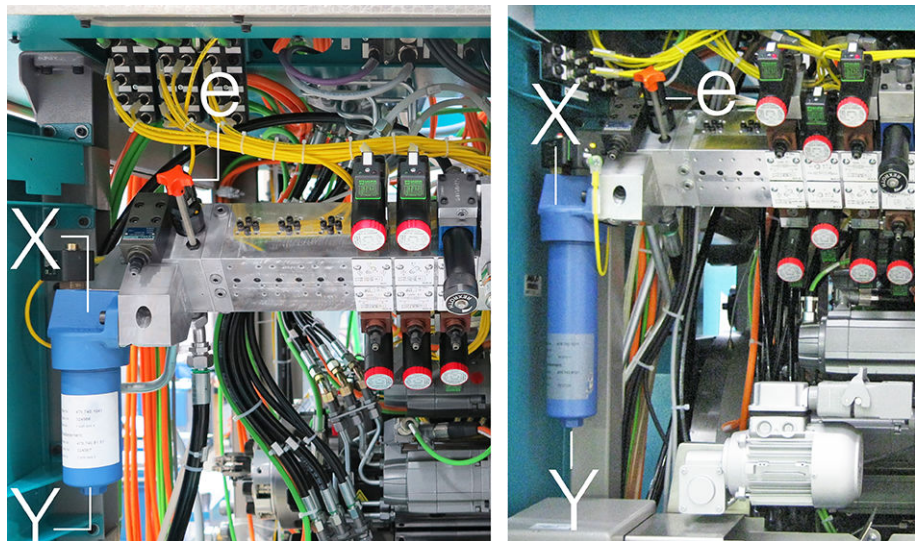

**Example: Hydraulic filter**

- X Hydraulic fluid filter
- Y Filter bowl
- e Accumulator drain valve

Using a wrench, loosen the filter bowl (Y) and remove it from the filter unit (X).

2.



Filters are hazardous waste and must be disposed of in a controlled manner.



Z  
**Example: Filter (Z)**

Empty filter bowl (Y) into prepared container. **Do not fill fluid from the filter bowl (Y) back into the tank!** Remove filter (Z).

3. Clean filter bowl (Y) and insert a new filter (Z). Reinstall the filter bowl and tighten **by hand until it stops**. Then back off the filter bowl 1/8 turn.



## CM048 - Replacing the hydrostatic filter



Carrying out the maintenance activities described below requires special knowledge. For this reason, these maintenance activities must only be carried out by staff that has received adequate training by the machine manufacturer!

### Orientation

Depending on the product and its level of equipment, a hydraulic filter is installed on the machine. The filters are provided with a sensor that signals malfunction or contamination to the control. If a fault is displayed on the control, the filter unit should be removed or replaced.



For all work in connection with operating fluids, the information in the data sheets of the respective manufacturers and the information in the document **Information on operating fluids** must be followed.

### Requirement



Only filters with retained particle sizes described in the fluid plans must be used.



Use only the original filters according to the spare or wear parts list.

A suitable container should be ready for the disposal of the filter and the residual oil in the filter bowl.

### Procedure

1.



Switch off the machine and lock it out.



**Example: Hydrostatic filter**

- X Hydrostatic filter
- Y Filter bowl

Using a wrench, loosen the filter bowl (Y) and remove it from the filter unit (X).

2.

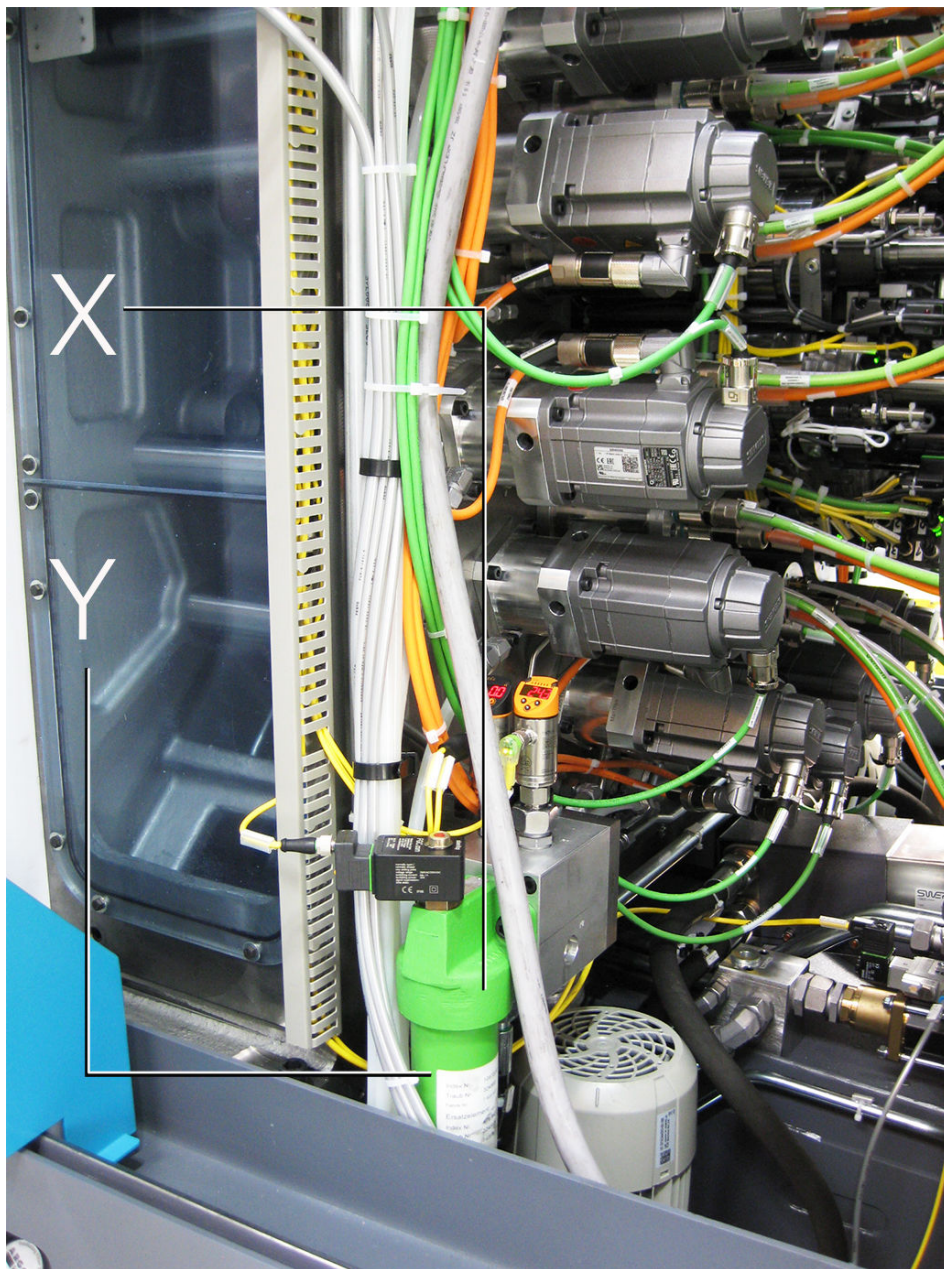

**Example: Hydrostatic filter**

- X Hydrostatic filter
- Y Filter bowl

Using a wrench, loosen the filter bowl (Y) and remove it from the filter unit (X).

3.



Filters are hazardous waste and must be disposed of in a controlled manner.



Z

Example: Filter (Z)

Empty filter bowl (Y) into prepared container. **Do not fill fluid from the filter bowl (Y) back into the tank!** Remove filter (Z).

4. Clean filter bowl (Y) and insert a new filter (Z). Reinstall the filter bowl and tighten **by hand until it stops**. Then back off the filter bowl 1/8 turn.

## CM052 - Fluid cooling - oil filters for heat exchangers, spindle carriers and synchronizers



Carrying out the maintenance activities described below requires special knowledge. For this reason, these maintenance activities must only be carried out by staff that has received adequate training by the machine manufacturer!

### Orientation

Depending on the product and its level of equipment, a filter element is installed on the machine. The filters are provided with a sensor that signals malfunction or contamination to the control. If a fault is displayed on the control, the filter unit should be removed or replaced.



For all work in connection with operating fluids, the information in the data sheets of the respective manufacturers and the information in the document **Information on operating fluids** must be followed.

### Requirement



Only filters with retained particle sizes described in the fluid plans must be used.



Use only the original filters according to the spare or wear parts list.

A suitable container should be ready for the disposal of the filter and the residual oil in the filter bowl.

### Procedure

1.



Switch off the machine and lock it out.

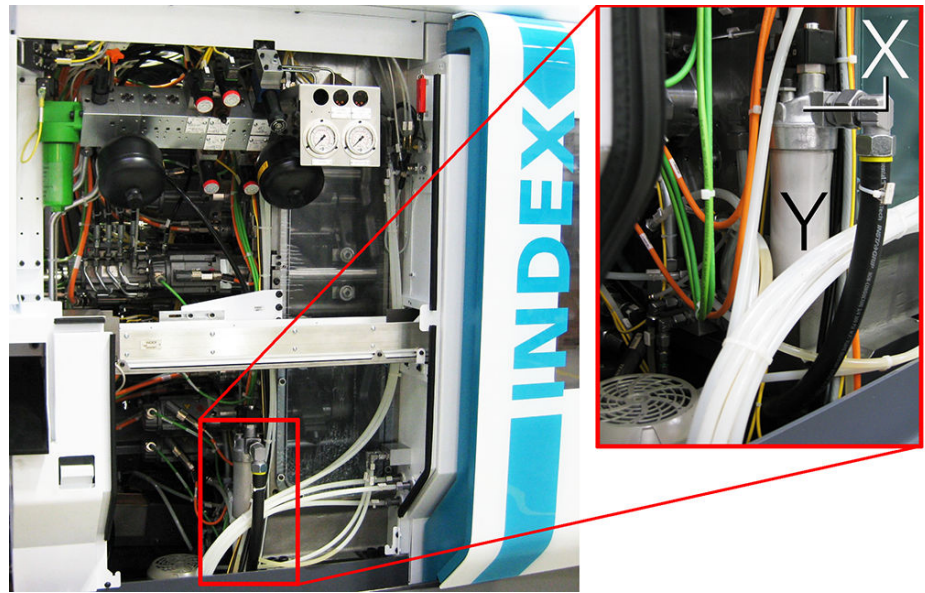

Example: Fluid cooling 1

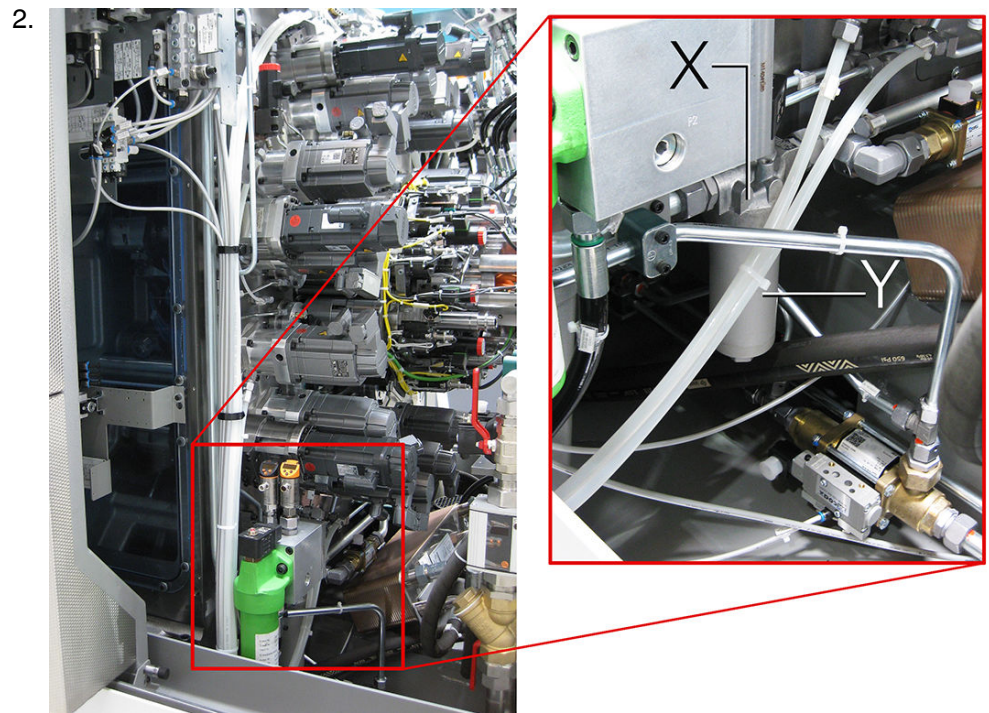

Example: Fluid cooling 2

- X Fluid cooling
- Y Filter bowl

Using a wrench, loosen the filter bowl (Y) and remove it from the filter unit (X).

3.



Filters are hazardous waste and must be disposed of in a controlled manner.



Z  
Example: Filter (Z)

Empty filter bowl (Y) into prepared container. **Do not fill fluid from the filter bowl (Y) back into the tank!** Remove filter (Z).

4. Clean filter bowl (Y) and insert a new filter (Z). Reinstall the filter bowl and tighten **by hand until it stops**. Then back off the filter bowl 1/8 turn.

## CM060 - Check pre-pressure of pressure accumulators



Carrying out the maintenance activities described below requires special knowledge. For this reason, these maintenance activities must be carried out only by authorized personnel of the manufacturer!

### Orientation



The activities described here are only permitted to be carried out after training or instruction by the manufacturer of the pressure accumulator.

A pressure accumulator consists of two chambers, a liquid and a gas section with a membrane as a separator. The liquid section is connected to the hydraulic circuit, so that the bubble reservoir is filled when the pressure rises, thereby compressing the gas. When the pressure drops, the compressed gas expands and displaces the stored pressurized liquid into the circulation. This ensures that the pressure level is maintained during load changes or temporary higher loads.



Screws on the hydraulic system, the connected components, and the supply lines must be tightened to the manufacturer's specified torques.

### Requirement



If there are ambiguities regarding the pressure values, be sure to consult the fluid diagrams included in the machine documentation/ documentation CD.



The values for pressure accumulator pre-tension of each machine type<sup>1</sup> are:

- MS16-6, MS22-6, MS22-8, MS24-6 **68 bar**
- MS32-6.2, MS32-6.3, MS40-6, MS40-8, MS52-6.3 **68 bar**

<sup>1)</sup> The pressures of the accumulator pre-tension is indicated on a label on the pressure accumulators.

### Procedure

1. Check the pressure accumulator. While the machine is switched on (not during a program or continuous run), press the emergency stop switch, while watching the system pressure gauge. The indication on the pressure gauge should drop noticeably within a few seconds. From a certain value (see info – Pretension pressures), the pressure drops rapidly to 0 bar. It is assumed that the accumulator pre-tension, the accumulator membrane, the gas fill, and thus the entire pressure accumulator are in order. If the pressure continuously drops to 0 bar within a few seconds without any clearly visible delay in the area of the pre-tension pressure, the bubble reservoir is defective and the pressure



accumulator needs to be replaced. Be sure to observe the maintenance interval IM... (5 years) and the associated maintenance activities at the end of the maintenance instructions

## CM080 - Inspection of water cooling equipment (option)



Carrying out the maintenance activities described below requires special knowledge. For this reason, these maintenance activities must only be carried out by staff that has received adequate training by the machine manufacturer!

### Orientation

Continuous inspection, maintenance and servicing of the installed water cooling equipment and related monitoring functions ensure trouble-free and efficient use of the machine. Any occurring malfunctions are detected at an early stage so they can be eliminated early before they result in damage to and long downtimes of the machine.



For all work in connection with operating fluids, the information in the data sheets of the respective manufacturers and the information in the document **Information on operating fluids** must be followed.

### Requirement

For inspection of the water cooling unit, the following equipment is required:

- device descriptions of the water cooling equipment (manufacture description) and the monitoring systems used.
- servicing, testing and maintenance schedules/logs of the customer.
- Use an ample supply of cleaning rags. - **Avoid using cotton waste and compressed air.**
- Various sizes of jaw and box wrenches, and Allen keys.

### Procedure

1. Review of the customer's service, inspection and maintenance schedules.
2. Check operating condition. Active – Inactive.
3. Check the supply lines of the system for leaks and/or damage.
4. Check water level in the tank, top up if necessary.
5. Check water filter and related sensors.

**Alternatively, the following procedure can be used!**

Clean water filter, and replace if necessary.

6. Check water flow monitoring.
7. Check water temperature and related sensors.

**CM140** - Inspection of the pneumatic system

Carrying out the maintenance activities described below requires special knowledge. For this reason, these maintenance activities must only be carried out by staff that has received adequate training by the machine manufacturer!

**Orientation**

Operating fluids such as hydraulic fluids, cooling lubricants, lubricating greases/oils are also subject to degradation or aging as the components involved in this process, and must therefore be serviced, refilled or replaced at regular intervals.

To ensure trouble-free operation, periodic checks of the pneumatic system are necessary.

- Check pressure setting on pressure gauge.
- Check fluid lines.
- Check silencers.
- Drain off condensate.
- Check filters, replace if necessary.

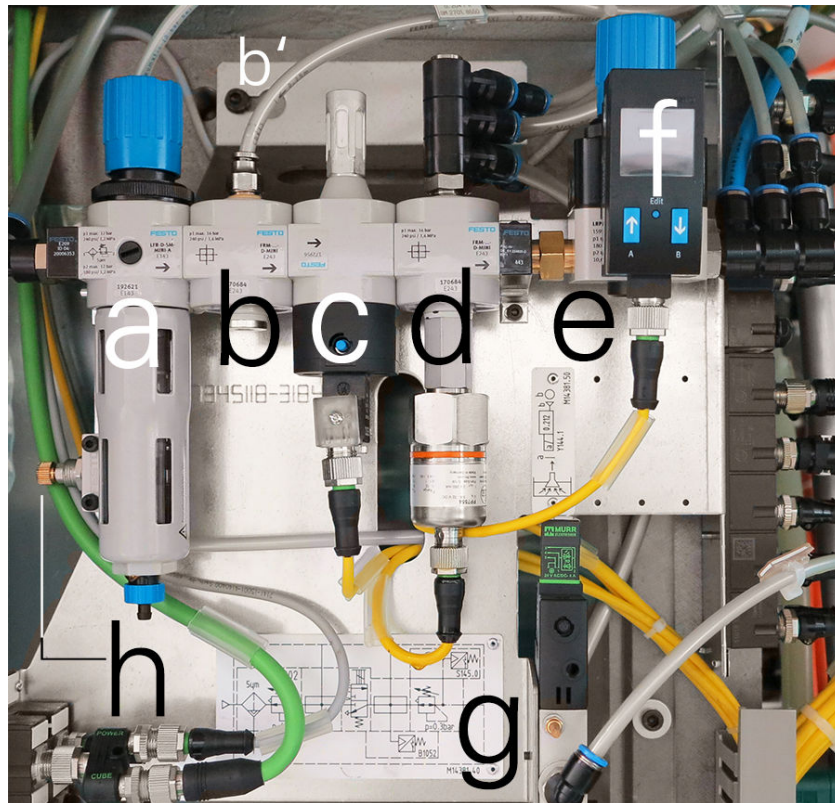

Example: Pneumatic maintenance unit by Festo

- a Filter regulating valve (factory set to 6 bar)
- b Branch module
- b' Branch fire shutter
- c Switch-on valve (electrically operated) with silencer (\*).
- d Branch module with pressure monitoring (factory set to min. 3.0 or 4.0 bar)
- e High-precision pressure regulating valve (factory set to 0.3 bar)
- f Pressure sensor
- g Switching valve for leakage oil extraction
- h Throttle for fire protection sensor
- (\* Check by manually pushing (using a ballpoint pen or similar) the yellow button of the switch-on valve (c)

## Requirement



The supply units of the pneumatic system and their components are pressurized. Before servicing the pneumatic system by switching off the (manual) switch-on valve, if available, depressurize or switch off the machine. Secure the machine against being switched on.

The maintenance of the pneumatic system requires the following auxiliary or working equipment:

- servicing, testing and maintenance schedules/logs of the customer.
- Use an ample supply of cleaning rags – **no cotton waste**.
- Air filter, silencer – **use only original parts**.
- Various sizes of jaw and box wrenches, and Allen keys.

## Procedure

1. Check fluid lines for damage such as buckling and abrasions. If necessary, replace fluid lines.

2. Check the fluid lines for air leaks.
3. Check components for damage.
4. Check the switch-on valve.
5. Check the condensate drain. Fully drain off condensate.
6. Check micro filters.

7.



**Example: Filter cartridge by FESTO**

Replace filter cartridge and verify filter fineness.

8.



**Example: Various silencer versions from FESTO**

Replace silencer.

9. Check pneumatic system pressure and related sensors.
10. Check pneumatic sealing air pressure and related sensors.

## CM180 - Checking the window pane

### Orientation

If the window pane shows damage in the form of cracks or severe deterioration, it must be replaced regardless of the information on the safety label. Initiate follow-up activities such as ordering and schedule the replacement with the customer.

### Requirement

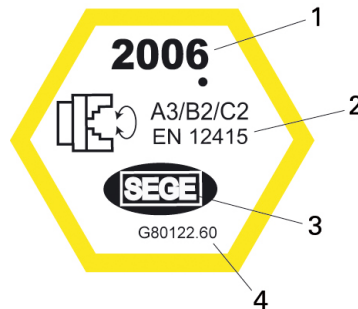

Example: Window pane label 2006

- 1 Year of manufacture
- 2 Protection class and EN standard
- 3 Manufacturer
- 4 INDEX part number



Check the inspection label: year of manufacture, resistance class, manufacturer (logo) of the window pane, **INDEX** part no.

### Procedure

1.



**Workpieces forcefully expelled from the workpiece clamping device or chips resulting from cutting operation are not held back by the destroyed pane.**

**Injury to the operating personnel, property damage, and damage to the machine.**

Continuous checking of the window pane and timely replacement – see the customer's service, inspection and maintenance schedules/logs.

Check window pane for damage.

2. Check tightness of sliding door with window pane. Check all the seals for damage/wear.
3. Check safety label and note replacement date.
4. Log any damage and order a new window pane, and schedule replacement with the customer.

**CM270** - Check MS guard switch/interlock

Carrying out the maintenance activities described below requires special knowledge. For this reason, these maintenance activities must only be carried out by staff that has received adequate training by the machine manufacturer!

**Orientation**

Different safety hood interlocks are fitted to the machine, depending on the equipment and machine type. These switches must be checked regularly.

**Requirement**

The following materials and equipment is required:

- servicing, testing and maintenance schedules/logs of the customer
- Various sizes of jaw and box wrenches, and Allen keys

**Procedure**

1.

**By-passing or overriding or use of defective safety devices****Danger to life and limb**

Regular check and maintenance of safety devices

Check front work area door for “Closed” position.

2. Check front work area doors for “Open” position.
3. Check rear work area door for “Closed” position.
4. Check rear work area door for “Open” position.
5. Check the seals of the work area doors.
6. Check the general condition of the work area door, e.g., for damage.
7. Log the checks in the service, inspection and maintenance schedules/logs of the customer/ **INDEX**.

## CM290 - Check IEMCA loading and unloading system



Carrying out the maintenance activities described below requires special knowledge. For this reason, these maintenance activities must only be carried out by staff that has received adequate training by the machine manufacturer!

### Orientation

To ensure a safe production process, the loading and unloading system must be regularly serviced and checked. This includes visual inspection of the work area door, visual inspection of the entire system and assessment of the general condition. Record the results in the customer's service, inspection and maintenance schedules/logs.



Due to different requirements and/or specifications of the respective manufacturers, be sure to review the respective manufacturer's documentation!

### Requirement



When working on or in the loading and unloading system, switch off the machine and secure it against being switched on again

The following materials and equipment is required:

- servicing, testing and maintenance schedules/logs of the customer
- Various sizes of jaw and box wrenches, and Allen keys
- Device descriptions of the loading and unloading system (manufacturer description) and the monitoring systems used

### Procedure

1. Check the driving pins.
2. Check the condition of the connecting coupling.
3. Check the IEMCA connection sleeve.
4. Check the bearings for the connection sleeve.
5. Check the guide rollers in the IEMCA.
6. Check the general condition of the work area door, e.g., for damage.
7. Log the checks in the service, inspection and maintenance schedules/logs of the customer/ **INDEX**.



**CM330** - Check gas springs on the control cabinet door, replace if necessary

## Orientation

To carry out work on the control cabinet of multi-spindle lathes, the cabinet doors are fitted with gas springs. These gas springs facilitate opening the heavy cabinet doors. In addition, they retain the cabinet doors in the upper position, thereby allowing safe working in the control cabinet. The options for checking the door are simple and can be carried out in a minimum of time.

## Requirement



Working with ladders



**The suitable ladders or platforms for this purpose must be secured to the eyelets provided in the control cabinet (see figures – Working with ladders).**

Additional eyelets can be screwed in, in the region of the control cabinet. Various screw-in points are provided for this, depending on the machine type.

## Procedure

1. Check the cabinet door when opening. If the cabinet doors can be opened without too much effort, it can be assumed that the doors or the gas springs are in order. If, however, the door greatly distorts when opening, this is a sign that one of the two gas springs is defective and must be replaced.

2.



Example: Gas pressure damper (ACE)

Check gas springs. In the second step, the condition of the gas springs should be inspected after opening the door. If one of the gas springs is highly wet, it must be replaced. In case of heavy soiling (depending on the environment), dirt adhering to the gas spring may embed into the seals, thereby damaging the piston rod and seals. Over time this leads to malfunction of the gas springs.

3.

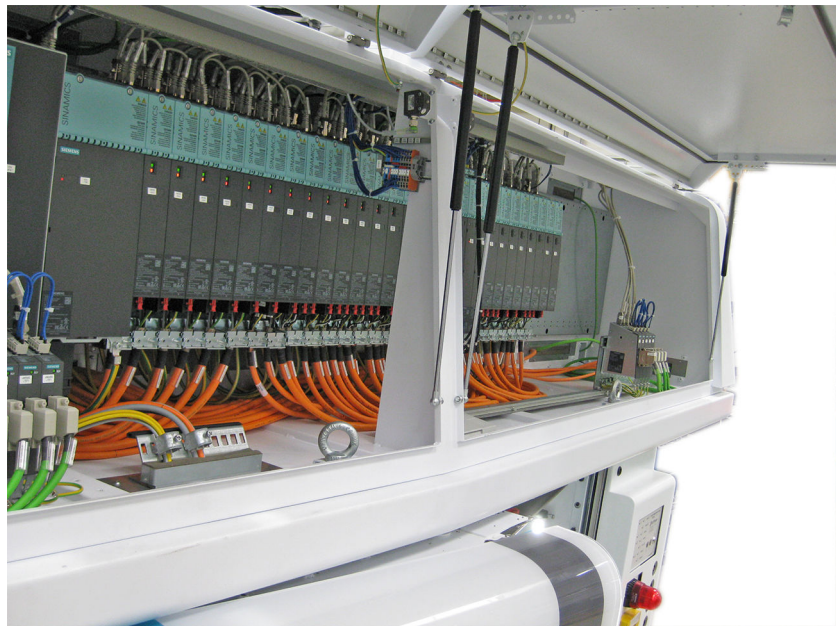

Example: Cabinet doors on a multi-spindle lathe

Checking the door after opening. Another test is that after opening the door and reaching the end position, the door should be horizontal and parallel to the machine. If the door bends on one side or even leaves its Open position, both gas springs or only the defective gas spring needs to be replaced.

4. Replace gas spring. If a gas spring needs to be replaced, be sure to read the manufacturer documentation. When installing the new gas spring, make sure that the installation position (flush) is oriented in the moving direction of the control cabinet door. Improper installation may cause immediate destruction of the new gas spring, such as bending or kinking.

## CM480 - Check operating panel for general condition

### Orientation

Check operating panel for general condition, keyboard, tightness

### Procedure

1.



Example: Control panel

Check operating terminal for tightness – free of oil and condensate.

2. Check control panel keyboard, and replace keys if necessary.
3. Record replacement date of the backup battery of the operating panel and the ARTIS card.

**Service Interval - 5 Years**

## Maintenance Summary - 5 Years



It is recommended to document the maintenance activities carried out by using the appropriate maintenance log. The maintenance log has the document number DIM028EN - 25.03.2024.

**IM020** - Replace the pressure accumulator

## IM020 - Replace the pressure accumulator



Carrying out the maintenance activities described below requires special knowledge. For this reason, these maintenance activities must be carried out only by authorized personnel of the manufacturer!

### Orientation



The activities described here are only permitted to be carried out after training or instruction by the manufacturer of the pressure accumulator.



According to the pressure equipment directive 2014/68/E4, the pressure accumulators built into the machine are of category I/ module A. They are provided with a CE mark by the manufacturer, and a declaration of conformity has been issued. Due to this categorization, the pressure accumulators must be subjected to an external and internal inspection and a strength test by a qualified person after a period of time recommended by the pressure accumulator's manufacturer. For pressure units with gas cushions, an internal inspection is recommended after 10 years at the latest. We recommend to replace the pressure accumulator after 5 years to avoid an internal inspection that is laborious and expensive for this size of pressure accumulator.



The machine owner/operator is obliged to check the pressure accumulator according to applicable rules and directives. Defective pressure accumulators must be disposed of according to applicable rules after they have been depressurized by a qualified technician. The guidelines and regulations applicable in the country of use must be followed.

The pressure accumulator must be replaced as specified in the user manual of the manufacturer.



Screws on the hydraulic system, the connected components, and the supply lines must be tightened to the manufacturer's specified torques.

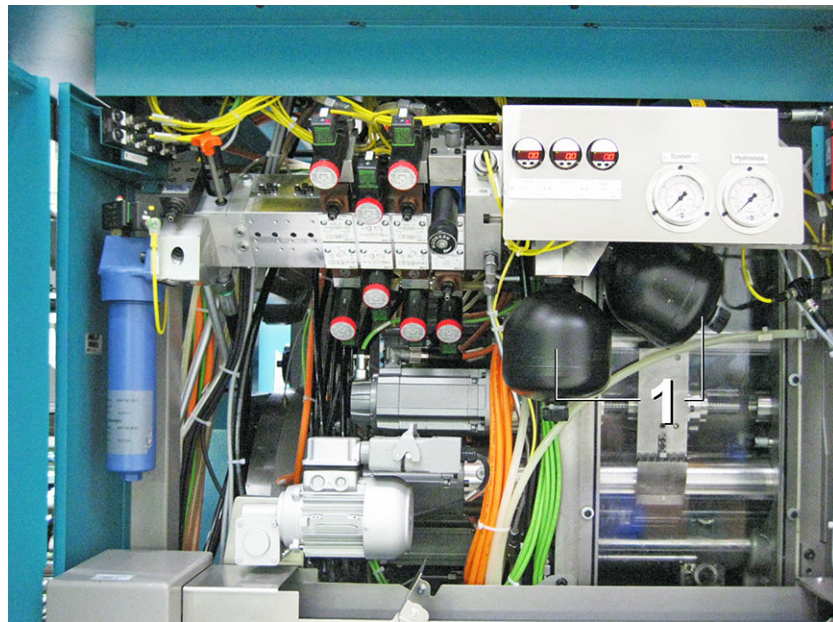

Example: Pressure accumulator MS40-8

1 Location of the pressure accumulators on an MS40-8

Depending on the machine type and its equipment, one or more pressure accumulators (1) are installed on the machine **(be sure to observe the hydraulic diagrams valid for this machine type)**.

## Requirement

**Caution for systems with pressure accumulators!** Pressure accumulators such as bubble reservoirs, diaphragm accumulators, piston accumulators may only be serviced by specialists and tested by “qualified persons for pressure vessels”. The Industrial Safety Regulation BetrSichV is binding here.



The locally valid guide lines and regulations must be taken into consideration.



Power off the machine, depressurize the hydraulic system by opening the accumulator relief valve(s), and protect against accidental power on.



Procedure

1.



**Example: Pressure accumulator**

Replace the pressure accumulator.



**Service Interval - 8 Years**

## Maintenance Summary - 8 Years



It is recommended to document the maintenance activities carried out by using the appropriate maintenance log. The maintenance log has the document number DIM028EN - 25.03.2024.

**JM030** - Replace the window pane

## JM030 - Replace the window pane

### Orientation



For safety reasons, it is recommended to obtain the window pane directly from the machine manufacturer or its country representative.

The window pane consists of four panes, the inner pane made of tempered glass, two center panes made of polycarbonate, and an outer pane also made of polycarbonate. The inner pane is relatively resistant to chemical substances. It can be cleaned with any commercially available cleaning agents. Only the center pane is essential for the impact resistance of the window pane. .

The polycarbonate panes are subject to **natural** aging and therefore must be subjected to regular visual inspection. Through contact with cooling lubricant, the aging process is accelerated even further.

### Requirement

A sealant is used at the factory to seal the new window pane. Either **Silicone 1200 of General Electric** or **Terostat MS 930 of Teroson**. If other sealing compounds than those described here are to be used, the equivalence must be confirmed in writing by the manufacturer.

### Procedure

1.



The following points must be observed:

- Warning, glass breakage!
- Secure the outer protective pane against falling down!
- Install new panes avoiding any tension!

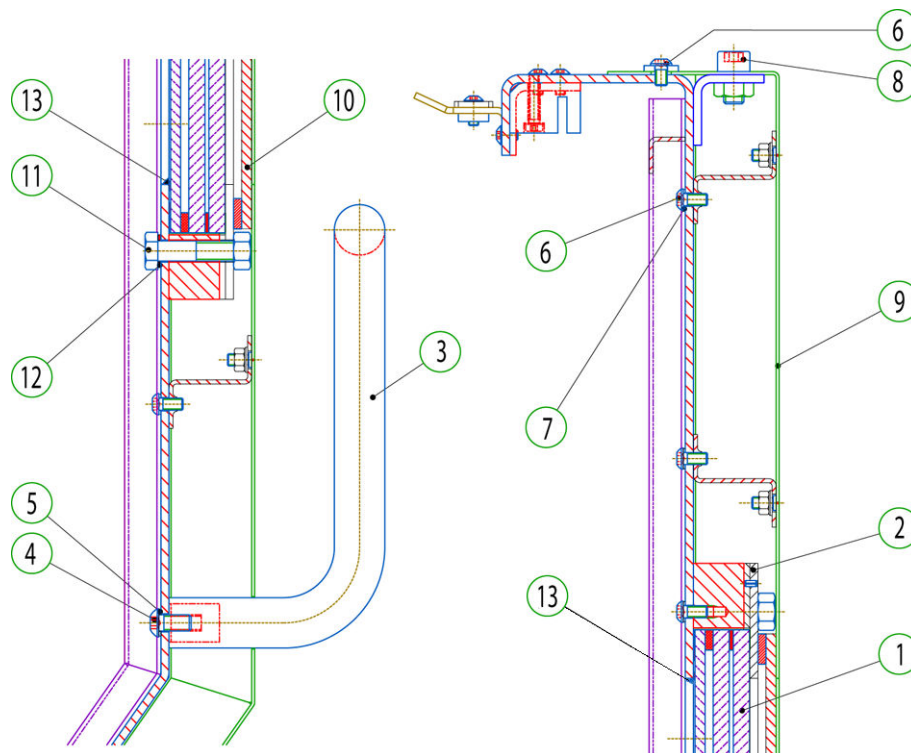

**Example: Window pane MS52-6.3**

- 1 Pane package (consisting of 2 polycarbonate panes and one pane of single-pane compound glass)
- 2 Frame
- 3 Handle
- 4 Oval head screw
- 5 USIT ring
- 6 Oval head screw
- 7 USIT ring
- 8 Cylinder head screw
- 9 Work area door cover
- 10 Outer protective pane
- 11 Hexagon head screws
- 12 USIT ring
- 13 Sealant (inside)

Remove the window pane. The following issues must be observed when replacing the window panes: **The sequence of the individual steps must be followed as described below.**

2. Cut open the sealant. Cut open the sealant (13) on the inner pane (1 – single-pane compound glass).
3. Remove oval-head screw (4), USIT ring (5), and door handle (3).
4. Loosen the oval-head screws (6) on the inside and remove the USIT ring (7).
5. Remove the cover of the work area door (9). On the upper side of the door, remove cylinder head screws (8) and oval-head screws (6) and remove the cover of the work area door (9).
6. Remove outer window pane (10).
7. Loosen hexagon head screws (11), remove USIT ring (12), and remove frame (2).
8. Remove window panes.
9. Insert new panes (1). Pay attention to the proper installation position.

10. Place frame (2) in position. Insert USIT ring (12) and install hexagon head screws (11).
11. Insert outer window pane (10).
12. Place cover of the work area door (9) in position.
13. Insert USIT ring (7) on the inside of the door and tighten oval-head screws (6).
14. Install cylinder head screws (8) and oval-head screws (6) on the upper side of the door.
15. Insert door handle (3). Insert USIT ring (5) and install oval head screws (4).
16. On the inside, seal the joint between the door panel and the window pane (1) all round with sealant (13).

# INDEX

**INDEX-Werke GmbH & Co. KG**  
**Hahn & Tessky**

Plochinger Str. 92  
D-73730 Esslingen, Germany

Fon +49 711 3191-0  
Fax +49 711 3191-587

[info@index-werke.de](mailto:info@index-werke.de)  
[www.index-werke.de](http://www.index-werke.de)